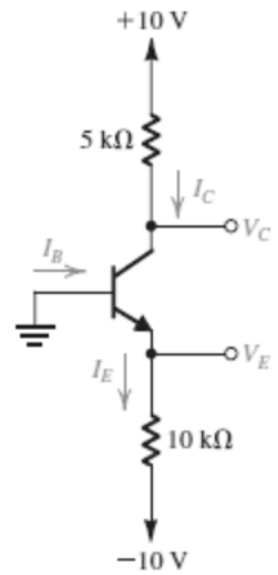

Example:

In the circuit shown in Fig. E6.13, the voltage at the emitter was measured and found to be -0.7 V . If $\beta = 50$, find I_E , I_B , I_C , and V_C .

Solution:

Graphical Representation of Transistor Characteristics:

It is sometimes useful to describe the transistor $i - v$ characteristics graphically. Figures below show the $i_C - v_{BE}$ characteristic, which is the exponential relationship

$$i_C = I_S e^{\frac{v_{BE}}{v_T}}$$

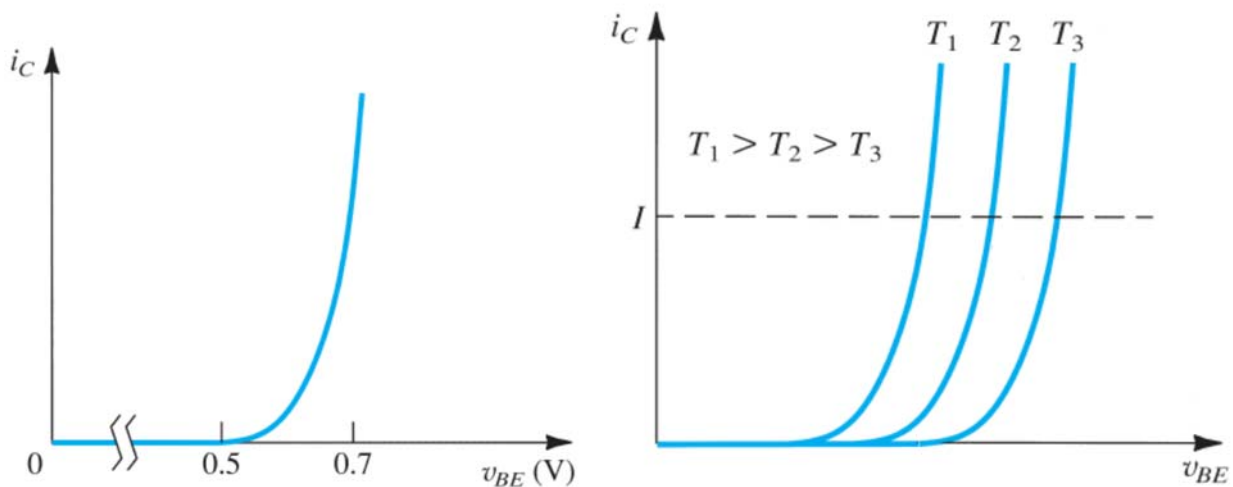

Example:

Consider a npn transistor with $v_{EB} = 0.7$ V at $i_E = 1$ mA. Let the base be grounded, the emitter be fed by a 2-mA constant-current source, and the collector be connected to a -5 -V supply through a 1-k Ω resistance. If the temperature increases by 30°C , find the changes in emitter and collector voltages. Neglect the effect of I_{CBO} .

Solution:

Ex: 6.15

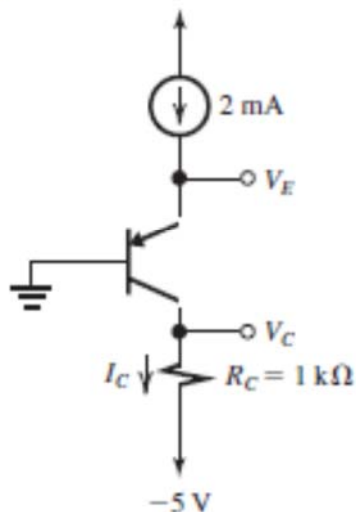

The transistor is operating at a constant emitter current. Thus, a change in temperature of $+30^\circ\text{C}$ results in a change in V_{EB} by

$$\Delta V_{EB} = -2 \text{ mV} \times 30 = -60 \text{ mV}$$

Thus,

$$\Delta V_E = -60 \text{ mV}$$

Since the collector current remains unchanged at αI_E , the collector voltage does not change:

$$\Delta V_C = 0 \text{ V}$$

Dependence of i_C on the Collector Voltage:

When operated in the active region, practical BJTs show some dependence of the collector current on the collector voltage. To see this dependence more clearly, consider the conceptual circuit shown in figure below. The transistor is connected in the common-emitter configuration; that is, here the emitter serves as a common terminal between the input and output ports.

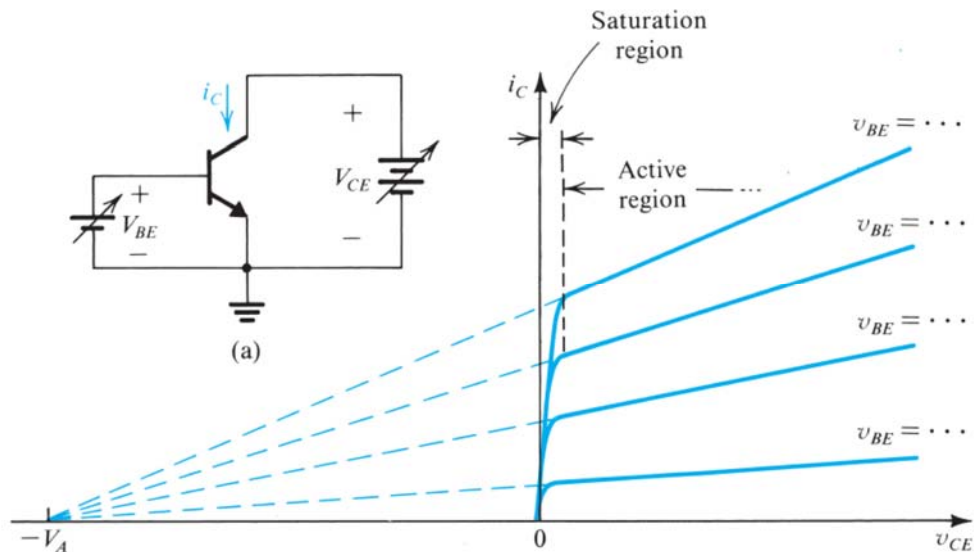

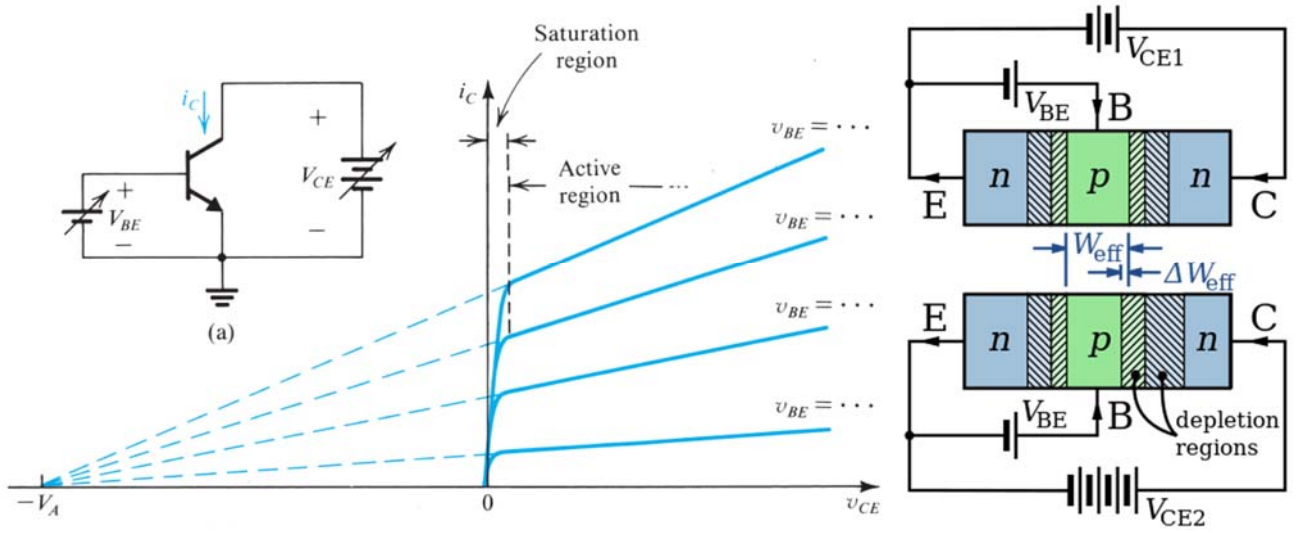

BJT Circuits at DC:

In the following examples we will use the simple model in which:

- $|V_{BE}|$ of a conducting transistor is 0.7 V and
- $|V_{CE}|$ of a saturated transistor is 0.2 V, and
- We will neglect the Early effect.

Table 6.3 Simplified Models for the Operation of the BJT in DC Circuits		
	<i>npn</i>	<i>pnp</i>
Active EBJ: Forward Biased CBJ: Reverse Biased		
Saturation EBJ: Forward Biased CBJ: Forward Biased		

First question is - In which mode is the transistor operating? In some cases, the answer will be obvious and in others it may not.

- For instance, a quick check of the terminal voltages will indicate whether the transistor is cut off or conducting.
- If it is conducting, we have to determine whether it is operating in the active mode or in saturation.
- **Procedure:** Assume that the transistor is operating in the active mode and, using the active-mode model in Table below, proceed to determine the various voltages and currents that correspond. Then check for consistency of the results with the assumption of active-mode operation; that is, is V_{CB} of an npn transistor greater than -0.4 V (or V_{CB} of a pnp transistor lower than 0.4 V)?
- If the answer is yes, then our task is complete.
- If the answer is no, assume saturation-mode operation and, using the saturation-mode model in Table below, proceed to determine currents and voltages

Example:

Consider the circuit shown in Fig. 6.23(a), which is redrawn in Fig. 6.23(b) to remind the reader of the convention employed throughout this book for indicating connections to dc sources. We wish to analyze this circuit to determine all node voltages and branch currents. We will assume that β is specified to be 100.

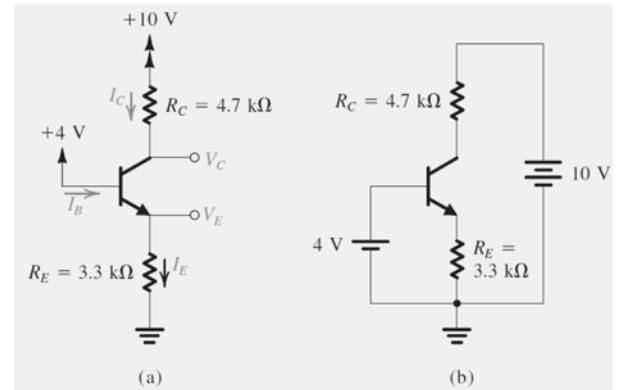

Example:

We wish to analyze the circuit in figure to determine the voltages at all nodes and the currents through all branches. Note that this circuit is identical to that considered in previous example, except that now the base voltage is zero.

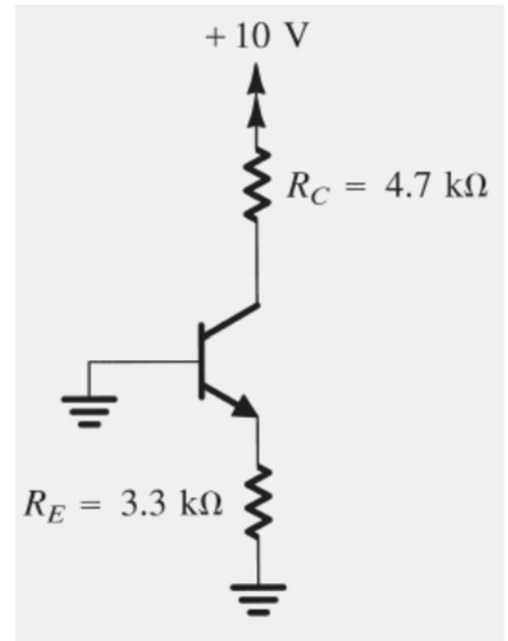

Example:

We want to analyze the circuit of figure below to determine the voltages at all nodes and the currents through all branches. Assume $\beta = 100$.

Solution:

