

# Chapter 3

## Transport Layer

### A note on the use of these ppt slides:

We're making these slides freely available to all (faculty, students, readers). They're in PowerPoint form so you see the animations; and can add, modify, and delete slides (including this one) and slide content to suit your needs. They obviously represent a *lot* of work on our part. In return for use, we only ask the following:

- ❖ If you use these slides (e.g., in a class) that you mention their source (after all, we'd like people to use our book!)
- ❖ If you post any slides on a www site, that you note that they are adapted from (or perhaps identical to) our slides, and note our copyright of this material.

Thanks and enjoy! JFK/KWR

© All material copyright 1996-2012  
J.F. Kurose and K.W. Ross, All Rights Reserved

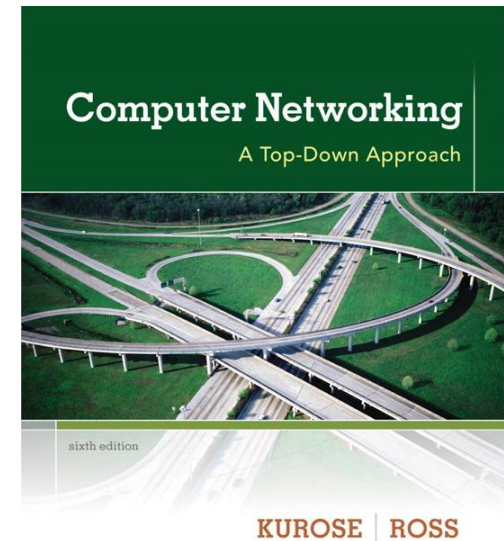

**Computer  
Networking: A Top  
Down Approach**  
6<sup>th</sup> edition  
Jim Kurose, Keith Ross  
Addison-Wesley  
March 2012

# Chapter 3: Transport Layer

## Goals:

- ❖ understand principles behind transport layer services:
  - multiplexing, de-multiplexing
  - reliable data transfer
  - flow control
  - congestion control
- ❖ learn about Internet transport layer protocols:
  - UDP: connectionless transport
  - TCP: connection-oriented reliable transport
  - TCP congestion control

# Transport services and protocols

- ❖ provide *logical communication* between **app processes running on different hosts**
- ❖ transport protocols run in end systems
  - **send side:** breaks app messages into **segments**, passes to network layer
  - **rcv side:** reassembles segments into messages, passes to app layer
- ❖ more than one transport protocol available to apps
  - Internet: TCP and UDP

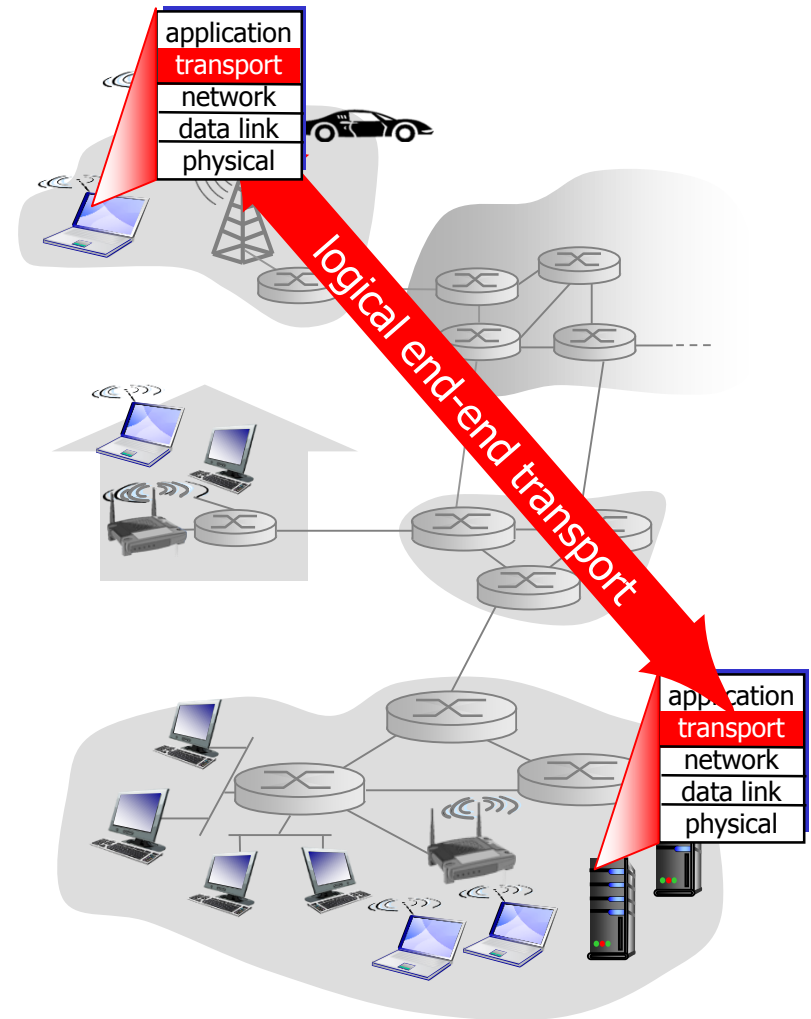

# Transport vs. network layer

- ❖ *network layer*: logical communication between hosts
- ❖ *transport layer*: logical communication between processes
  - relies on, enhances, network layer services

## *household analogy:*

- 12 kids in Ann's house sending letters to 12 kids in Bill's house:
- ❖ hosts = houses
  - ❖ processes = kids
  - ❖ app messages = letters in envelopes
  - ❖ transport protocol = Ann and Bill who demux to in-house siblings
  - ❖ network-layer protocol = postal service

# Internet transport-layer protocols

- ❖ reliable, in-order delivery (TCP)
  - congestion control
  - flow control
  - connection setup
- ❖ unreliable, unordered delivery: UDP
  - no-frills extension of “best-effort” IP
- ❖ services not available:
  - delay guarantees
  - bandwidth guarantees

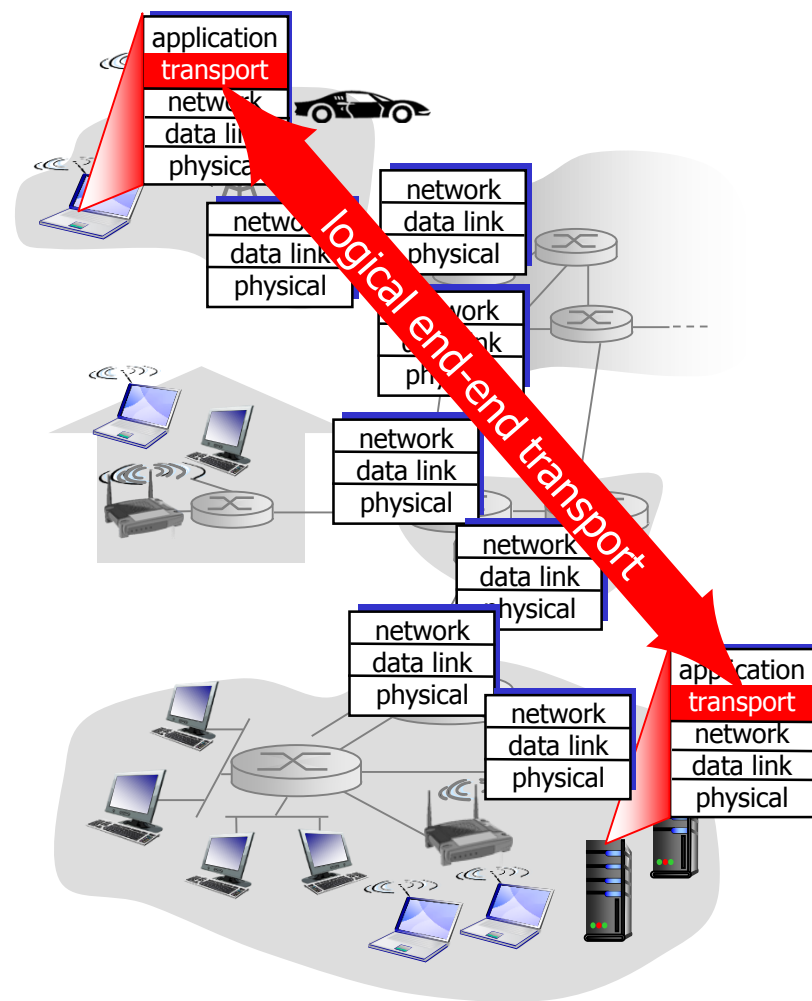

# Multiplexing/demultiplexing

*multiplexing at sender:*  
handle data from multiple sockets, add transport header (later used for demultiplexing)

*demultiplexing at receiver:*  
use header info to deliver received segments to correct socket

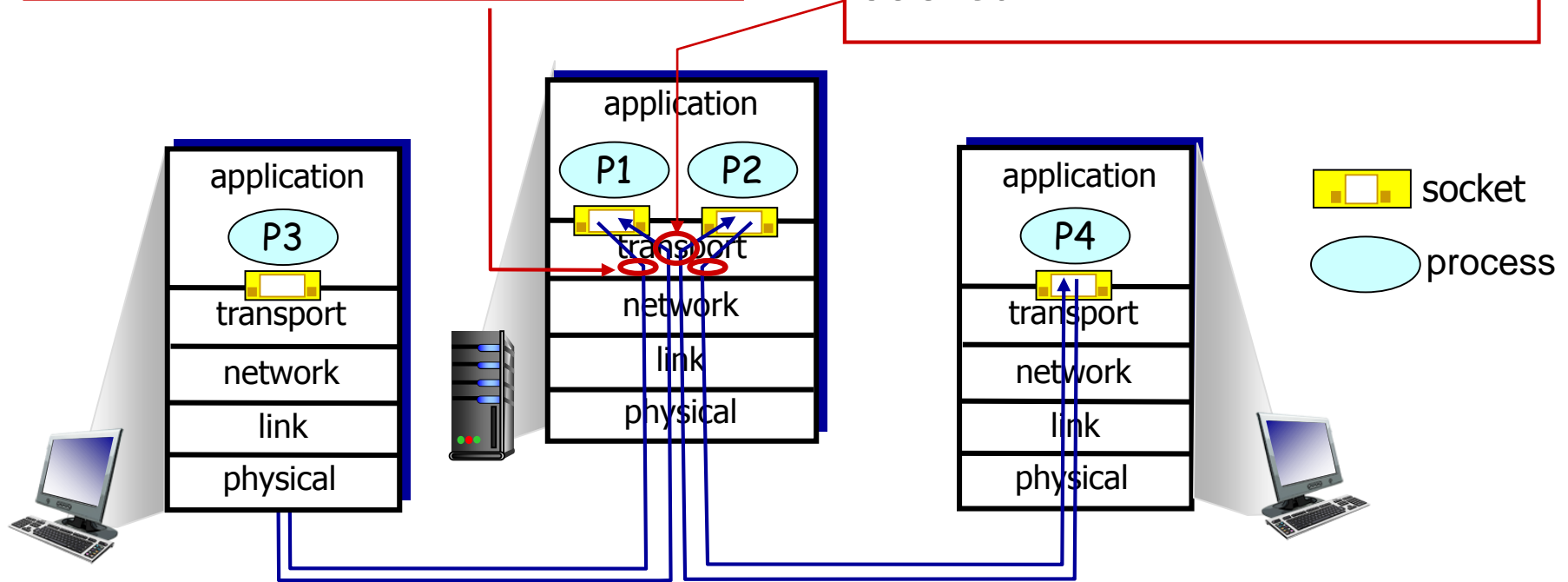

# How demultiplexing works

## ❖ host receives IP datagrams

- each datagram has source IP address, destination IP address
- each datagram carries one transport-layer segment
- each segment has source, destination port number

## ❖ host uses *IP addresses & port numbers* to direct segment to appropriate socket

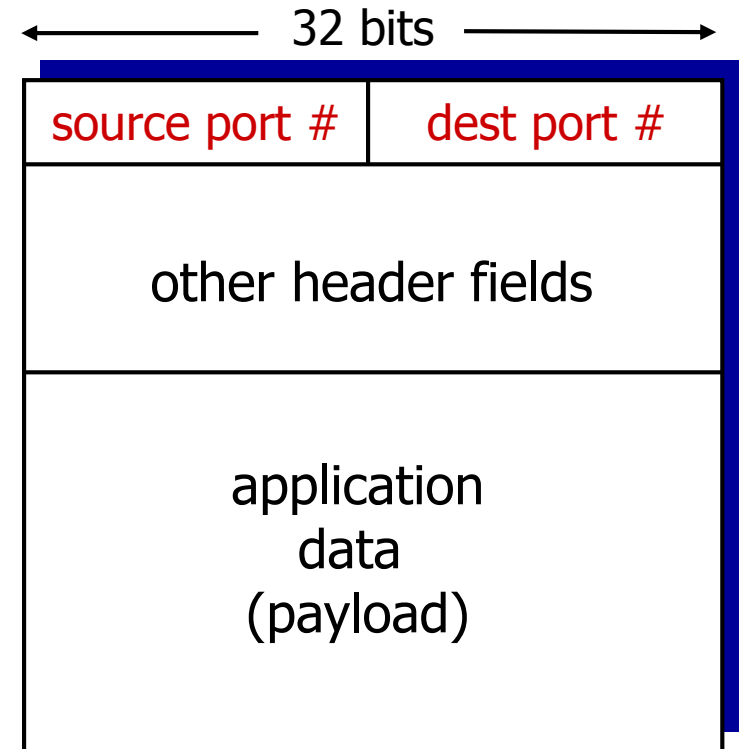

TCP/UDP segment format

# Connectionless demultiplexing

- ❖ *recall*: created socket has host-local port #:

```
DatagramSocket mySocket1  
= new DatagramSocket(12534);
```

- ❖ *recall*: when creating datagram to send into UDP socket, must specify
  - destination IP address
  - destination port #

- ❖ when host receives UDP segment:

- checks destination port # in segment
- directs UDP segment to socket with that port #



IP datagrams with *same dest. port #*, but different source IP addresses and/or source port numbers will be directed to *same socket* at dest.

# Connectionless demux: example

```
DatagramSocket  
mySocket2 = new  
DatagramSocket  
(9157);
```

```
DatagramSocket  
serverSocket = new  
DatagramSocket  
(6428);
```

```
DatagramSocket  
mySocket1 = new  
DatagramSocket  
(5775);
```

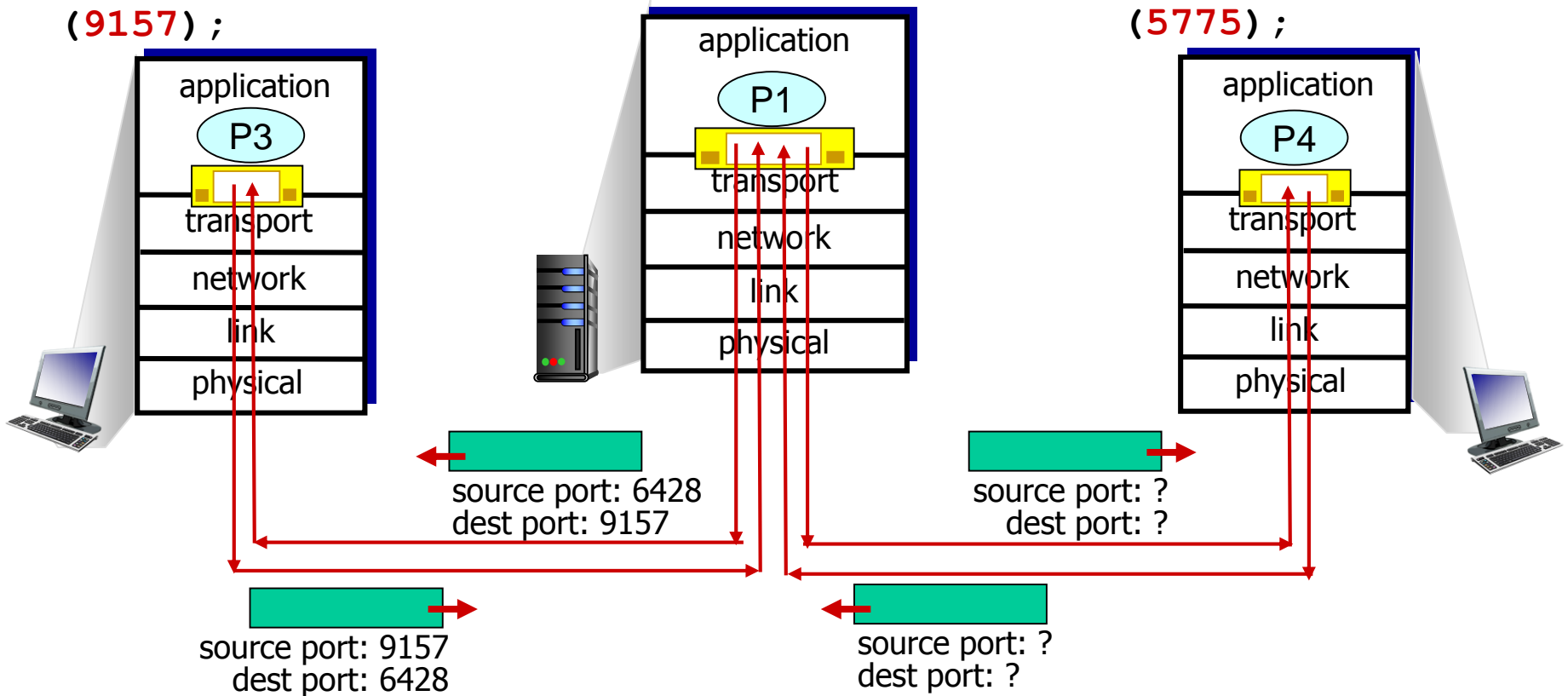

# Connection-oriented demux

- ❖ TCP socket identified by 4-tuple:
  - source IP address
  - source port number
  - dest IP address
  - dest port number
- ❖ demux: receiver uses all four values to direct segment to appropriate socket
- ❖ server host may support many simultaneous TCP sockets:
  - each socket identified by its own 4-tuple
- ❖ web servers have different sockets for each connecting client
  - non-persistent HTTP will have different socket for each request

# Connection-oriented demux: example

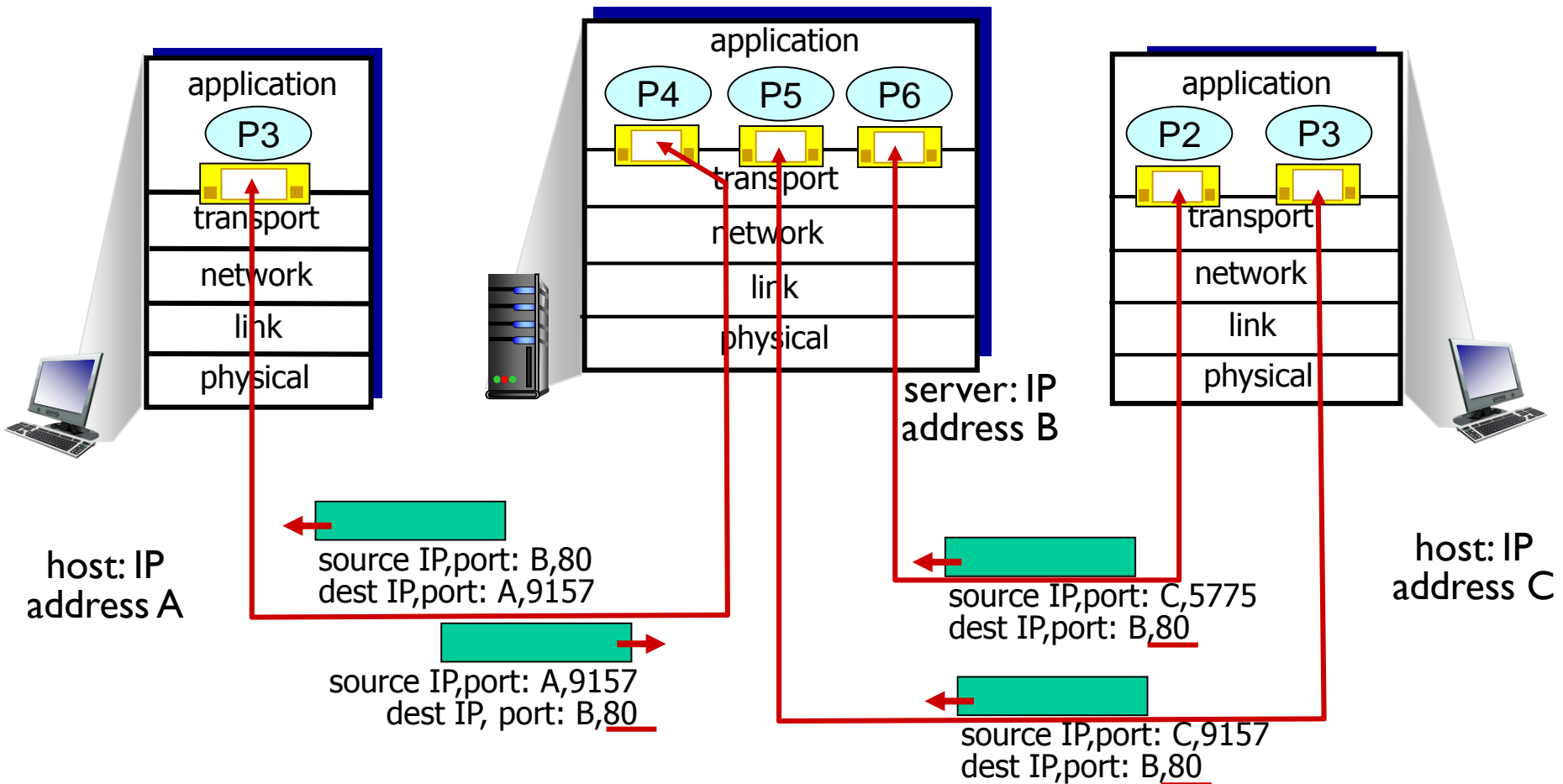

three segments, all destined to IP address: B,  
dest port: 80 are demultiplexed to *different* sockets

# Connection-oriented demux: example

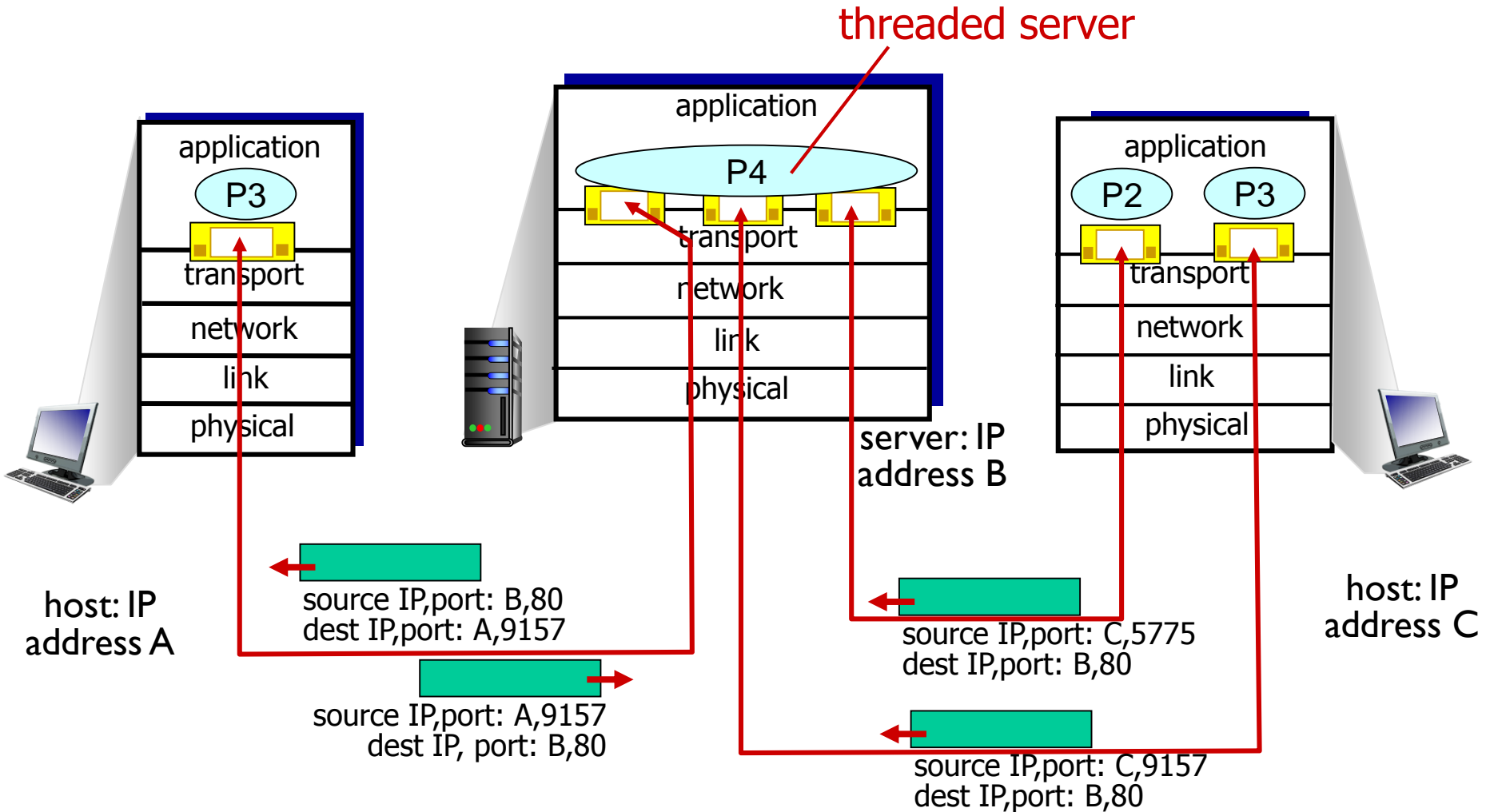

## Connectionless Transport UDP: User Datagram Protocol [RFC 768]

---

- ❖ “no frills,” “bare bones” Internet transport protocol
- ❖ “best effort” service, UDP segments may be:
  - lost
  - delivered out-of-order to app
- ❖ *connectionless*:
  - no handshaking between UDP sender, receiver
  - each UDP segment handled independently of others
- ❖ UDP use:
  - streaming multimedia apps (loss tolerant, rate sensitive)
  - DNS
  - SNMP
- ❖ reliable transfer over UDP:
  - add reliability at application layer
  - application-specific error recovery!

# UDP: segment header

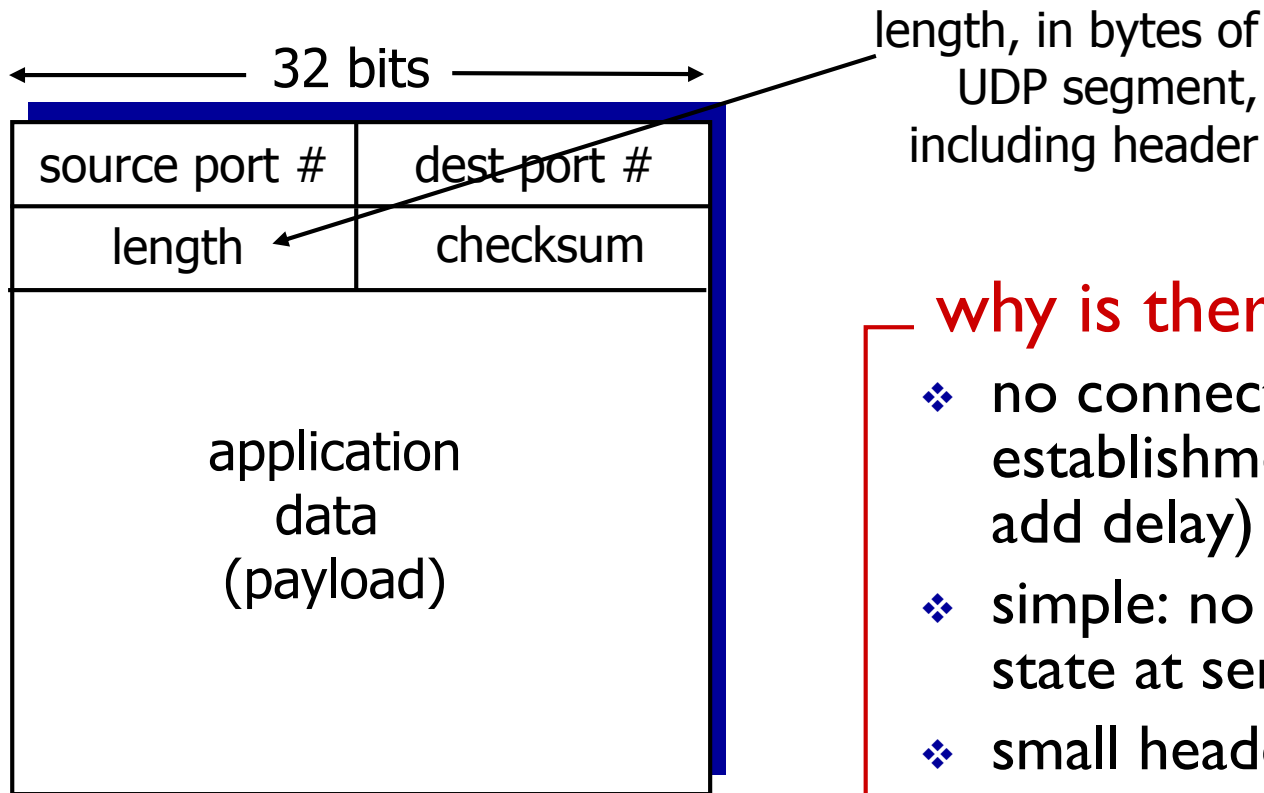

UDP segment format

## why is there a UDP?

- ❖ no connection establishment (which can add delay)
- ❖ simple: no connection state at sender, receiver
- ❖ small header size
- ❖ no congestion control: UDP can blast away as fast as desired

# UDP checksum

*Goal:* detect “errors” (e.g., flipped bits) in transmitted segment

## sender:

- ❖ treat segment contents, including header fields, as sequence of 16-bit integers
- ❖ checksum: addition (one's complement sum) of segment contents
- ❖ sender puts checksum value into UDP checksum field

## receiver:

- ❖ compute checksum of received segment
- ❖ check if computed checksum equals checksum field value:
  - NO - error detected
  - YES - no error detected.  
*But maybe errors nonetheless? More later*
- ....

# Internet checksum: example

example: add two 16-bit integers

	1	1	1	0	0	1	1	0	0	1	1	0	0	1	1	0	
	1	1	0	1	0	1	0	1	0	1	0	1	0	1	0	1	
<hr/>																	
wraparound	1	1	0	1	1	1	0	1	1	1	0	1	1	1	0	1	1
<hr/>																	
sum	1	0	1	1	1	0	1	1	1	0	1	1	1	1	0	0	
checksum	0	1	0	0	0	1	0	0	0	1	0	0	0	0	1	1	

*Note:* when adding numbers, a carryout from the most significant bit needs to be added to the result

# Principles of reliable data transfer

- ❖ important in application, transport, link layers
  - top-10 list of important networking topics!

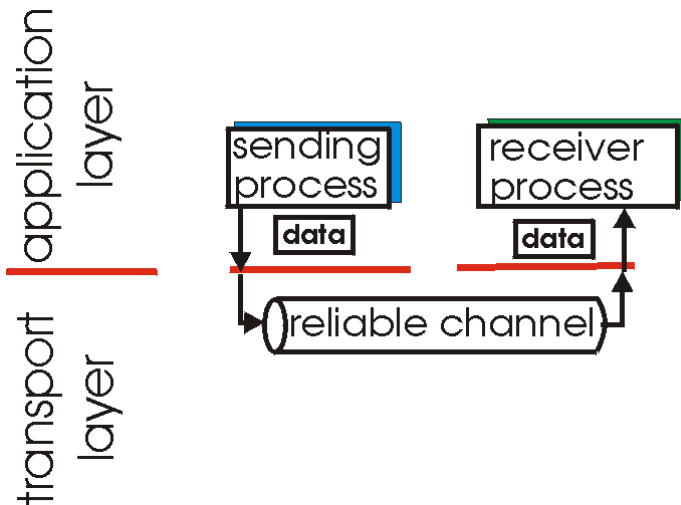

(a) provided service

- ❖ characteristics of unreliable channel will determine complexity of reliable data transfer protocol (rdt)

# Principles of reliable data transfer

- ❖ important in application, transport, link layers
  - top-10 list of important networking topics!

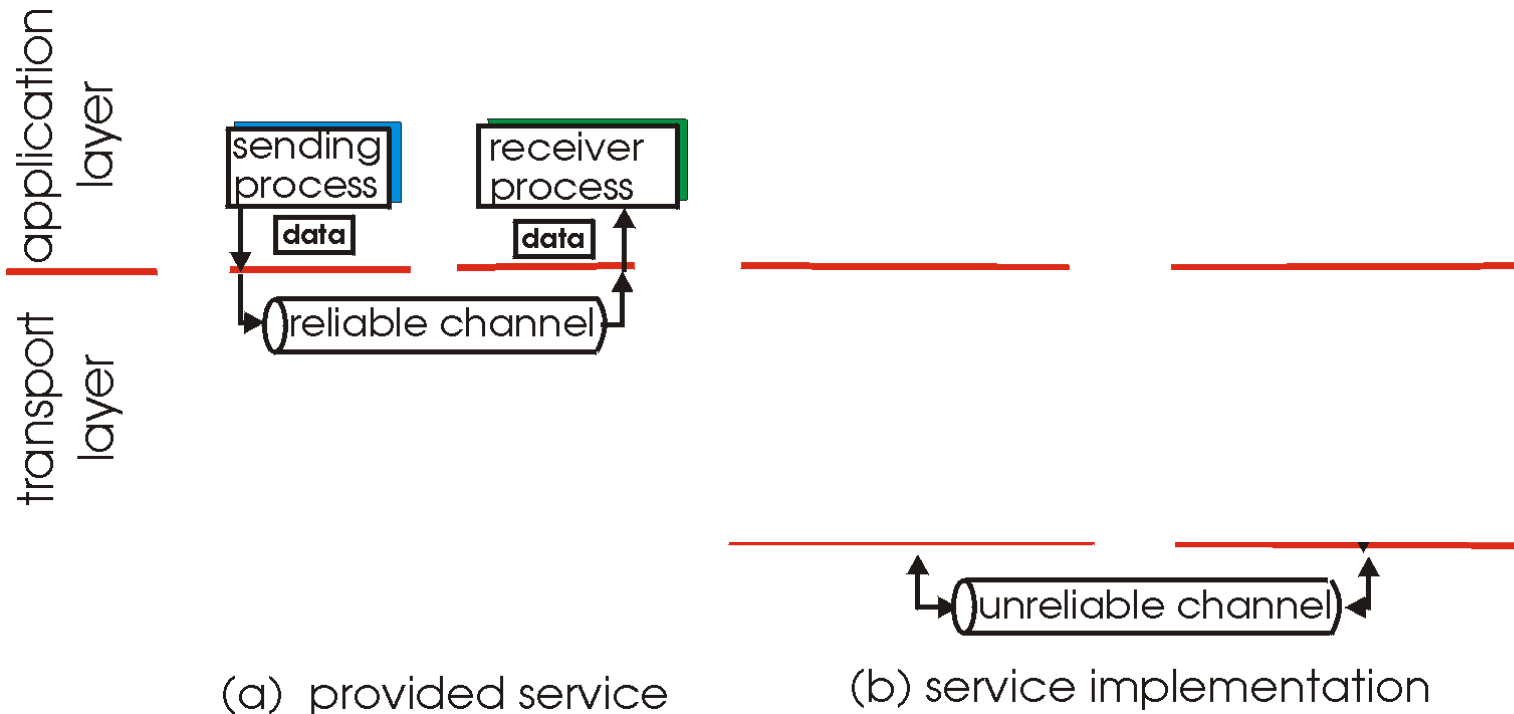

- ❖ characteristics of unreliable channel will determine complexity of reliable data transfer protocol (**rdt**)

# Principles of reliable data transfer (rdt)

- ❖ important in application, transport, link layers
  - top-10 list of important networking topics!

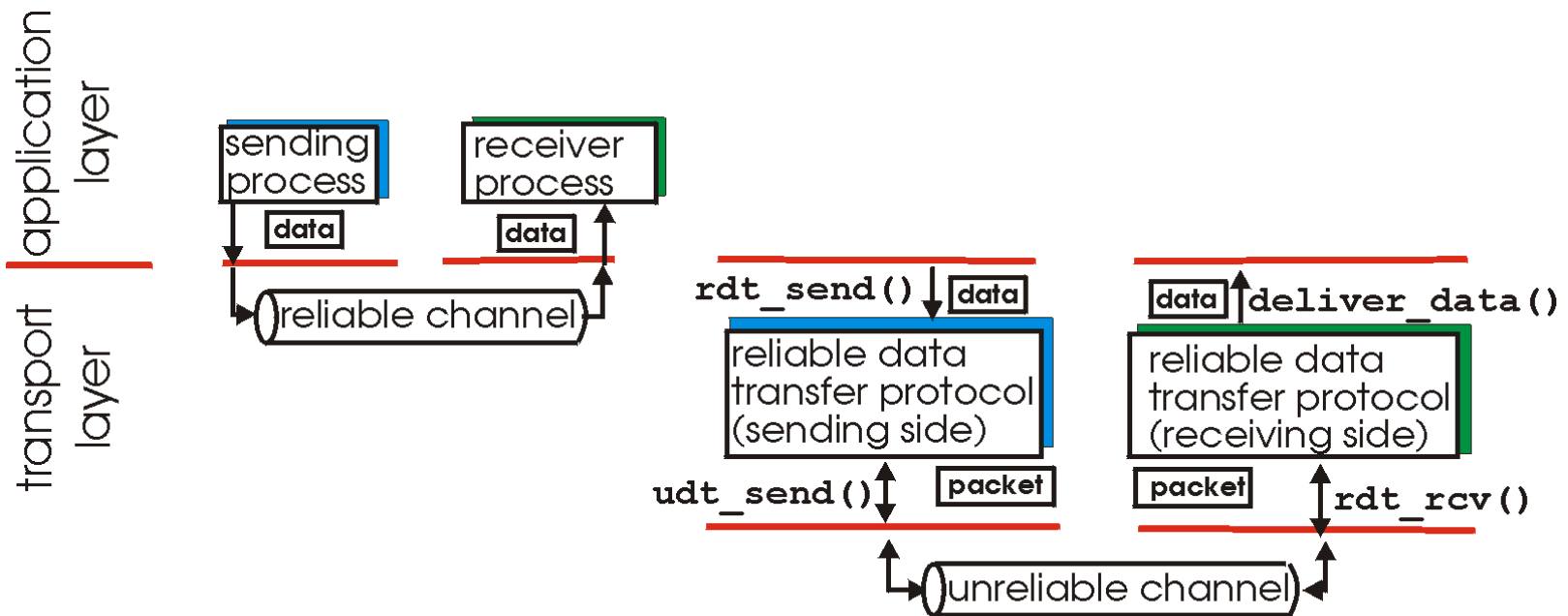

(a) provided service

(b) service implementation

- ❖ characteristics of unreliable channel will determine complexity of reliable data transfer protocol (rdt)

# Reliable data transfer: getting started

**rdt\_send()** : called from above, (e.g., by app.). Passed data to deliver to receiver upper layer

**deliver\_data()** : called by **rdt** to deliver data to upper

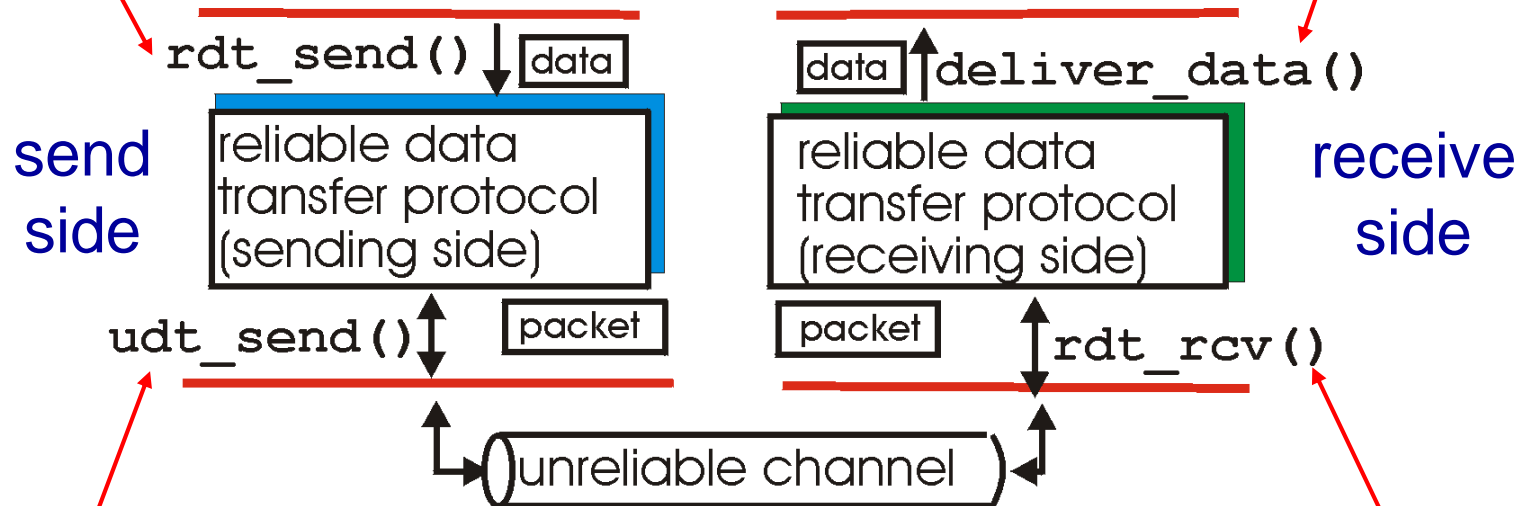

**udt\_send()** : called by rdt, to transfer packet over unreliable channel to receiver

**rdt\_rcv()** : called when packet arrives on rcv-side of channel

# Reliable data transfer: getting started

we' ll:

- ❖ incrementally develop sender, receiver sides of reliable data transfer protocol (rdt)
- ❖ consider only unidirectional data transfer
  - but control info will flow on both directions!
- ❖ use **f**inite **s**tate **m**achines (FSM) to specify sender, receiver

**state:** when in this “state” next state uniquely determined by next event

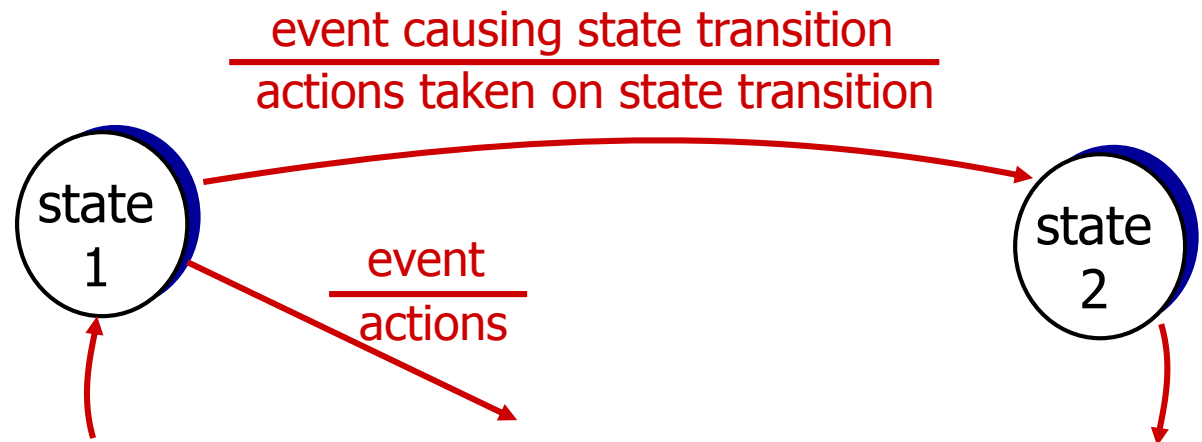

# rdt 1.0: reliable transfer over a reliable channel

- ❖ underlying channel perfectly reliable
  - no bit errors
  - no loss of packets
- ❖ separate FSMs for sender, receiver:
  - sender sends data into underlying channel
  - receiver reads data from underlying channel

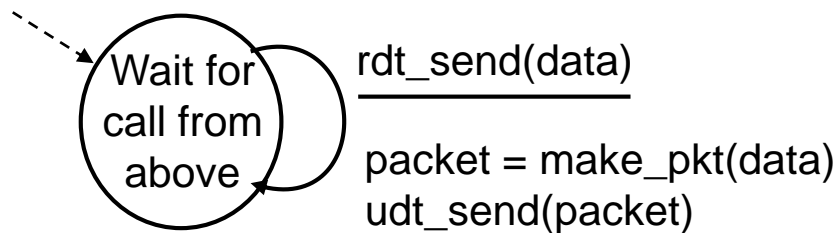

sender

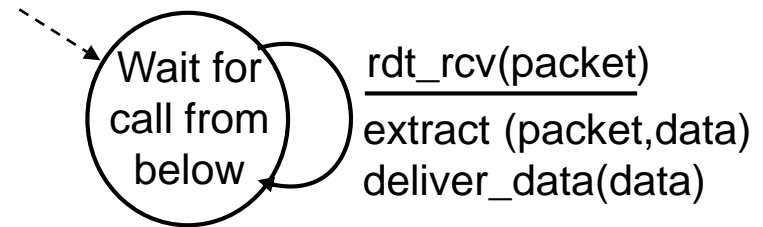

receiver

# rdt2.0: channel with bit errors

- ❖ underlying channel may flip bits in packet
  - checksum to detect bit errors
- ❖ *the question: how to recover from errors:*

*How do humans recover from “errors”  
during conversation?*

# rdt2.0: channel with bit errors

- ❖ underlying channel may flip bits in packet
  - checksum to detect bit errors
- ❖ *the question*: how to recover from errors:
  - *acknowledgements (ACKs)*: receiver explicitly tells sender that pkt received OK
  - *negative acknowledgements (NAKs)*: receiver explicitly tells sender that pkt had errors
  - sender retransmits pkt on receipt of NAK
- ❖ new mechanisms in `rdt2.0` (beyond `rdt1.0`):
  - error detection
  - feedback: control msgs (ACK,NAK) from receiver to sender

# rdt2.0: FSM (Finite State Machine) specification

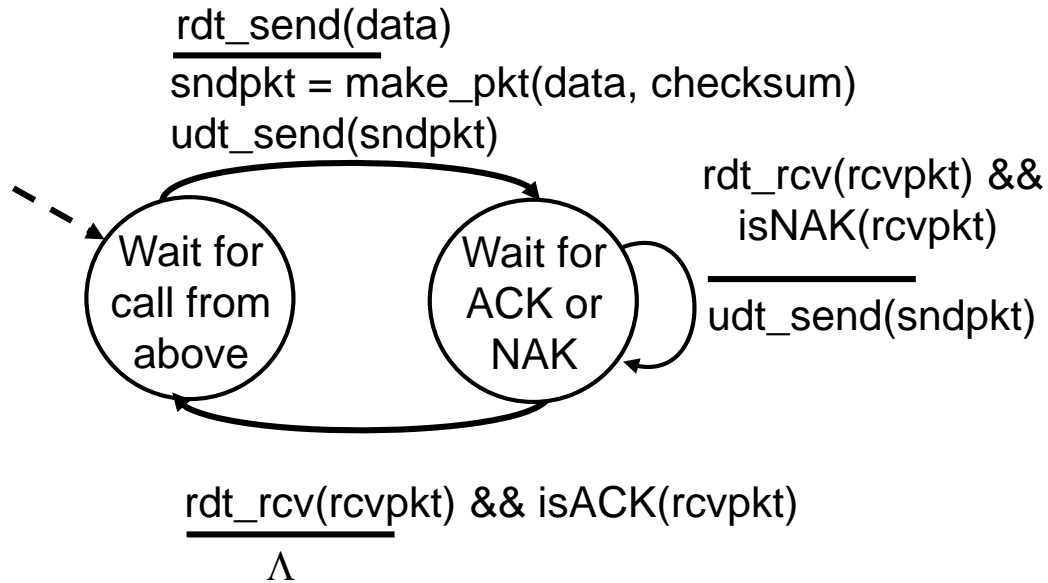

sender

receiver

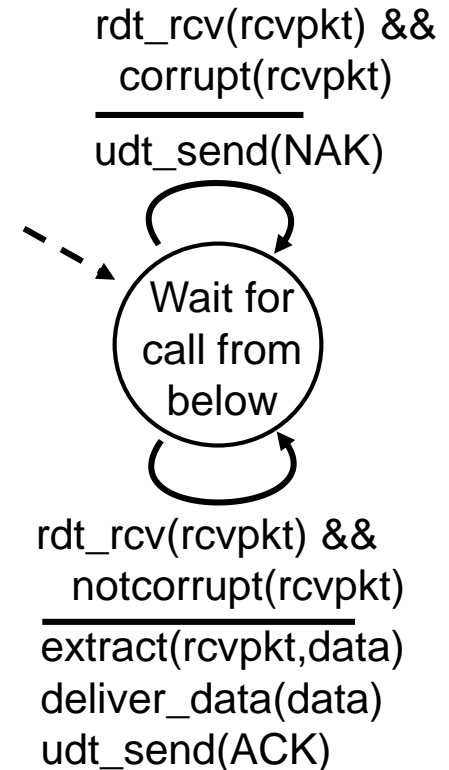

# rdt2.0: operation with no errors

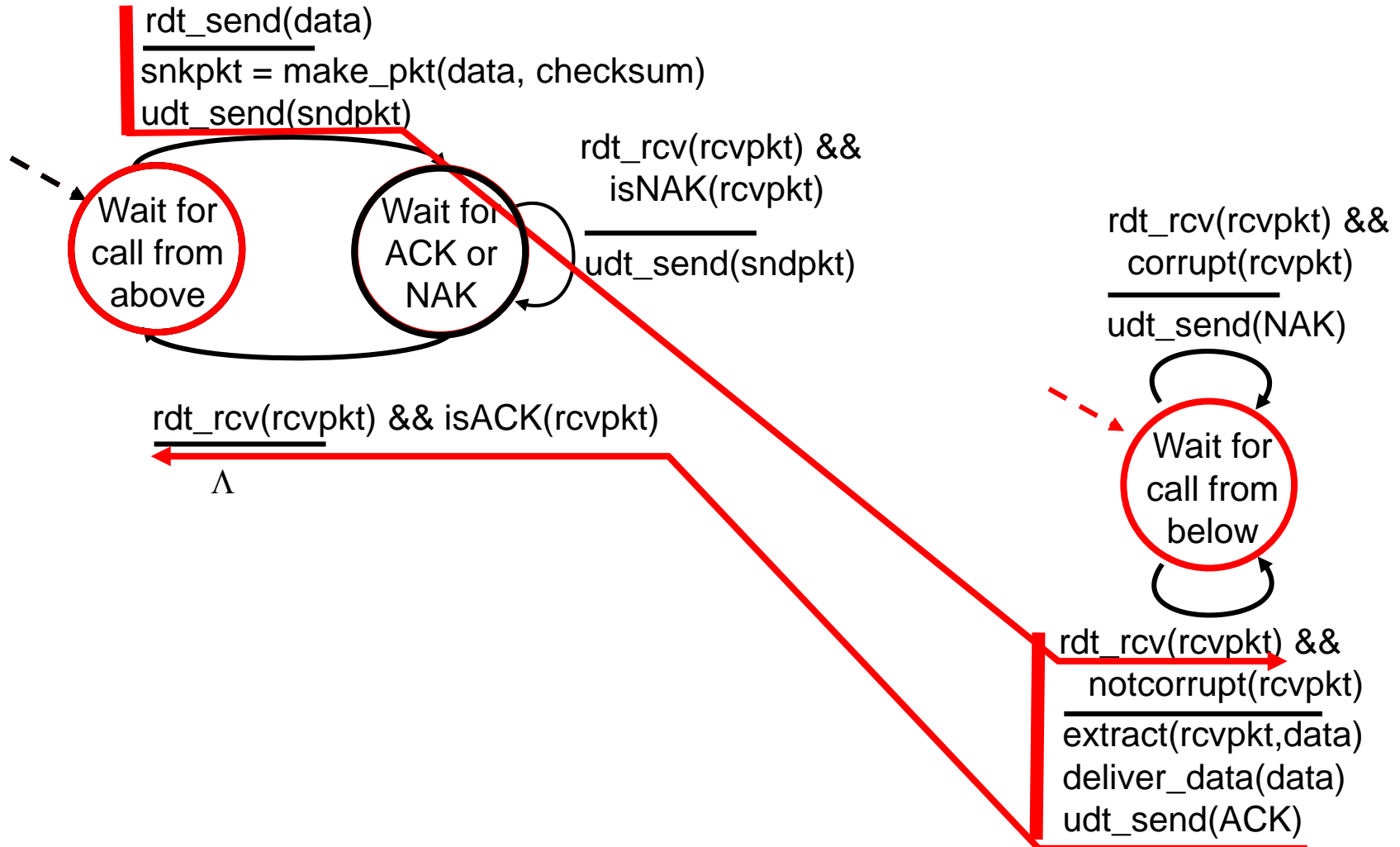

# rdt2.0: error scenario

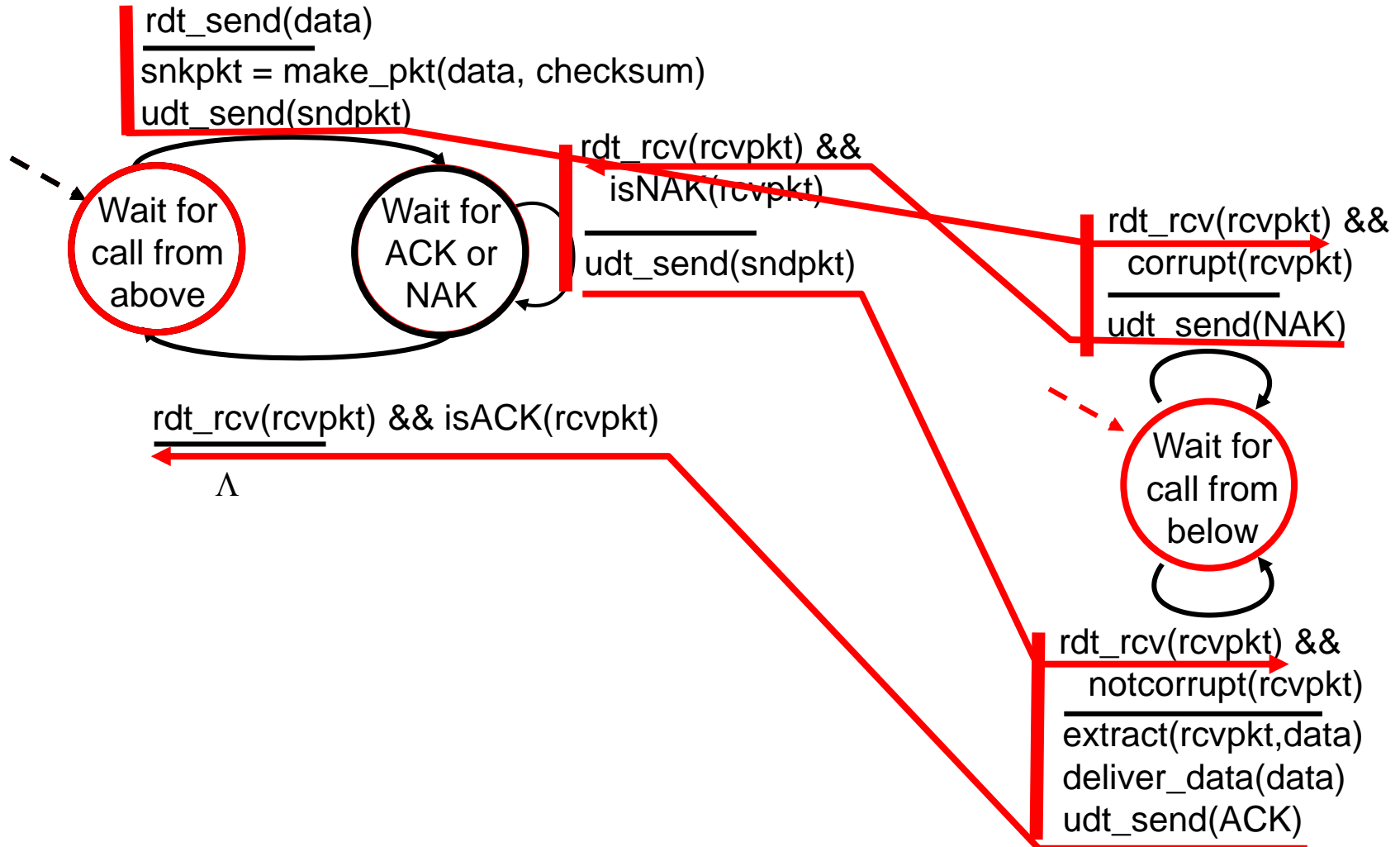

# rdt2.0 has a fatal flaw!

## what happens if ACK/NAK corrupted?

- ❖ sender doesn't know what happened at receiver!
- ❖ can't just retransmit: possible duplicate

## handling duplicates:

- ❖ sender retransmits current pkt if ACK/NAK corrupted
- ❖ sender adds *sequence number* to each pkt
- ❖ receiver discards (doesn't deliver up) duplicate pkt

## stop and wait

sender sends one packet,  
then waits for receiver  
response

# rdt2.1: sender, handles garbled ACK/NAKs

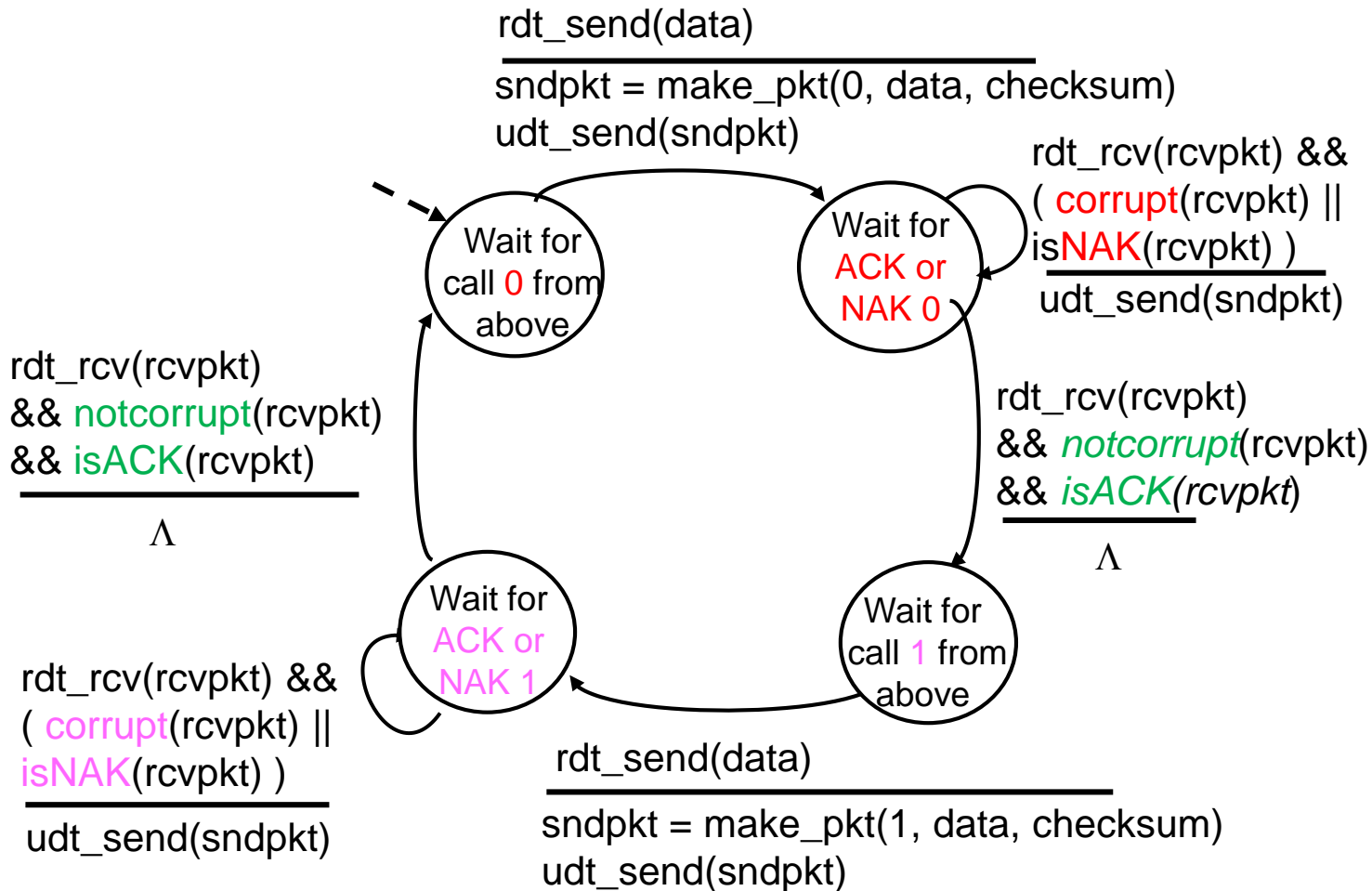

# rdt2.1: receiver, handles garbled ACK/NAKs

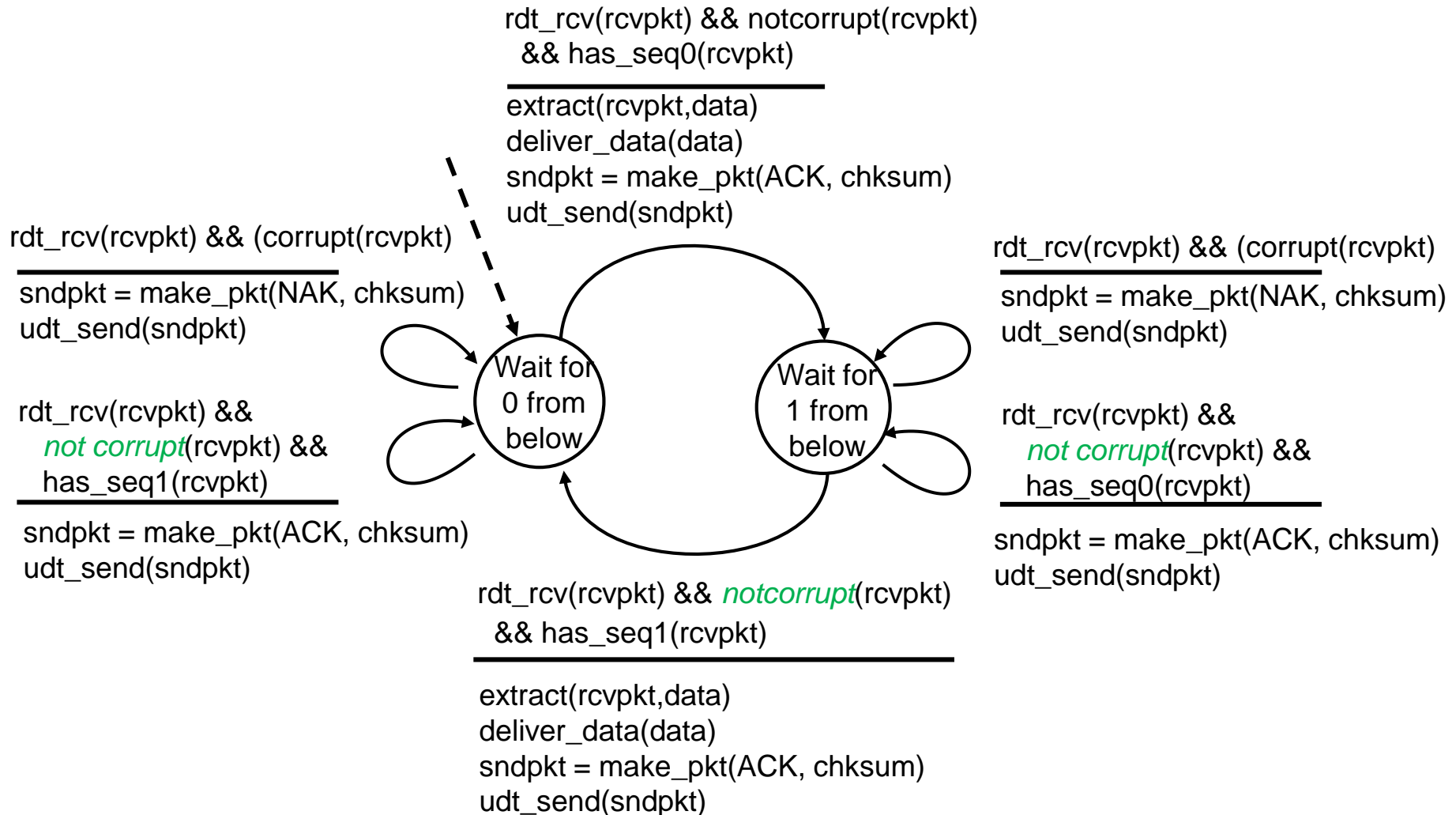

# rdt2.1: discussion

## sender:

- ❖ seq # added to pkt
- ❖ two seq. #'s (0,1) will suffice. Why?
- ❖ must check if received ACK/NAK corrupted
- ❖ twice as many states
  - state must “remember” whether “expected” pkt should have seq # of 0 or 1

## receiver:

- ❖ must check if received packet is duplicate
  - state indicates whether 0 or 1 is expected pkt seq #
- ❖ note: receiver can *not* know if its last ACK/NAK received OK at sender

# rdt2.2: a NAK-free protocol

- ❖ same functionality as rdt2.1, using ACKs only
- ❖ instead of NAK, receiver sends ACK for last pkt received OK
  - receiver must *explicitly* include seq # of pkt being ACKed
- ❖ duplicate ACK at sender results in same action as NAK: *retransmit current pkt*

# rdt2.2: sender, receiver fragments

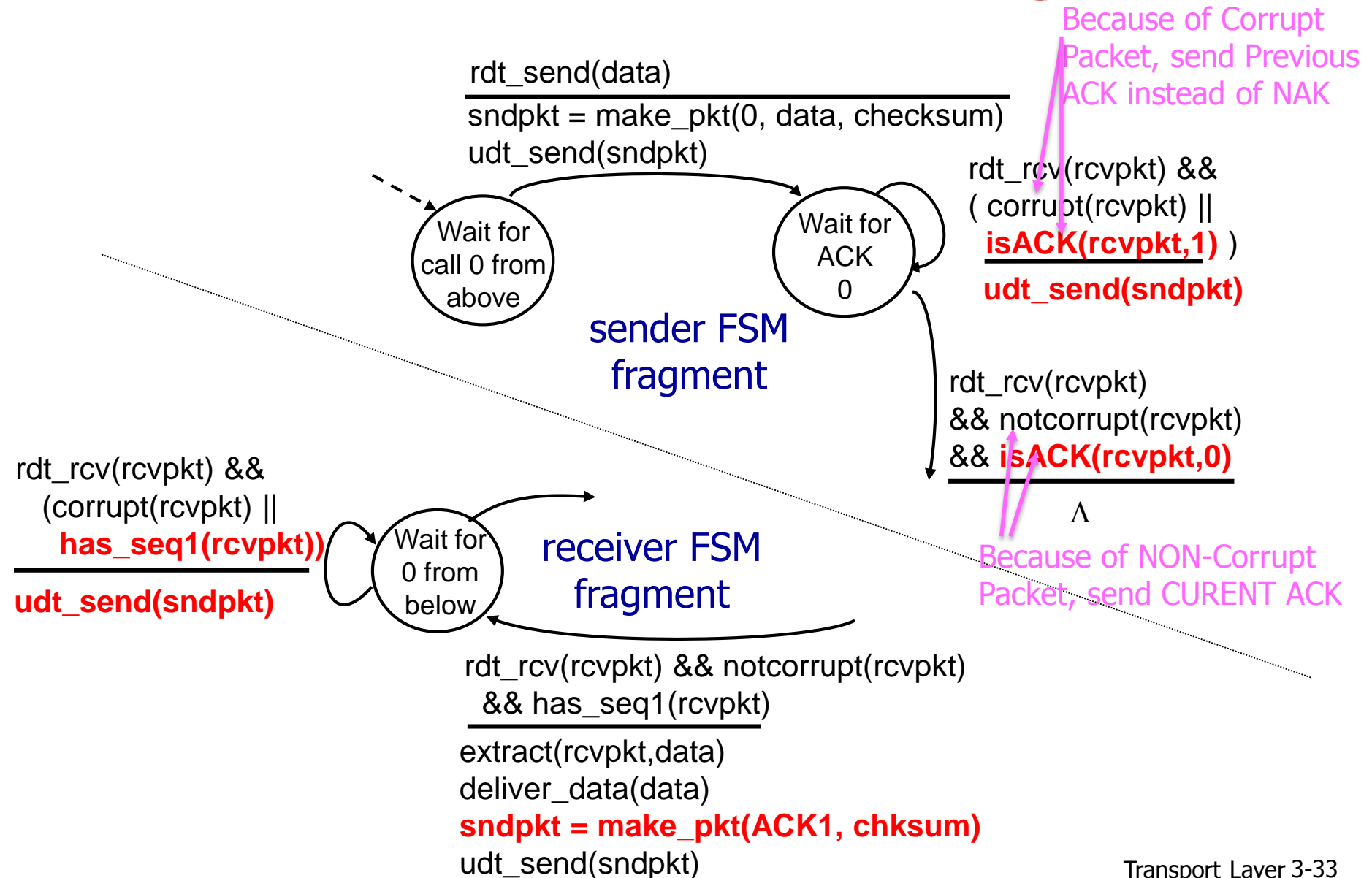

# rdt3.0 : channels with errors and loss

## new assumption:

underlying channel can also lose packets (data, ACKs)

- checksum, seq. #, ACKs, retransmissions will be of help ... but not enough

*What is that reasonable time ? And how do you determine it ?*

approach: sender waits “reasonable” amount of time for ACK

- ❖ retransmits if no ACK received in this time
- ❖ if pkt (or ACK) just delayed (not lost):
  - retransmission will be duplicate, but seq. #'s already handles this
  - receiver must specify seq # of pkt being ACKed
- ❖ requires countdown timer

# rdt3.0 sender

Corrupt .. ACK(1) but looking for ACK(0)

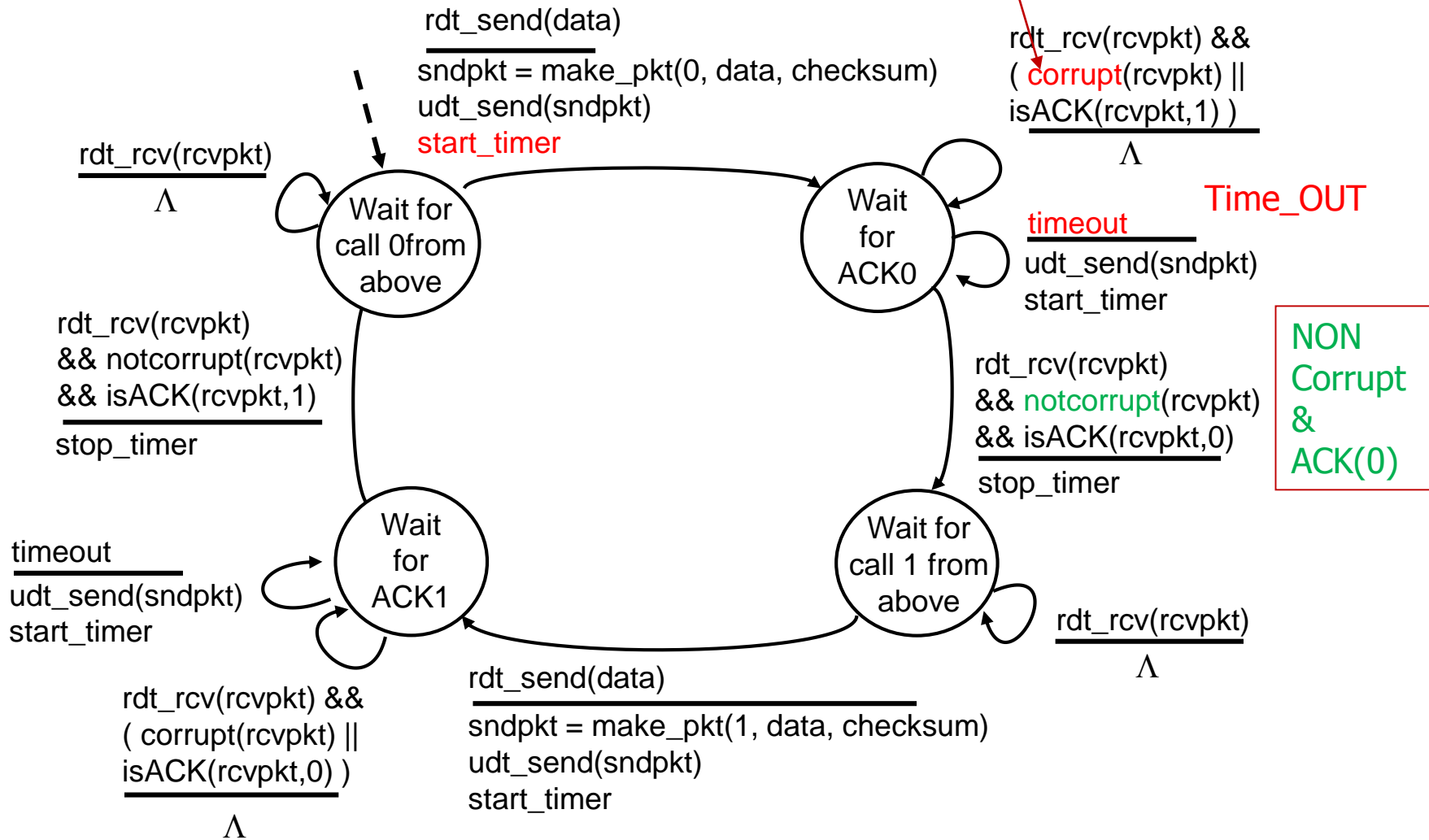



# rdt3.0 in action

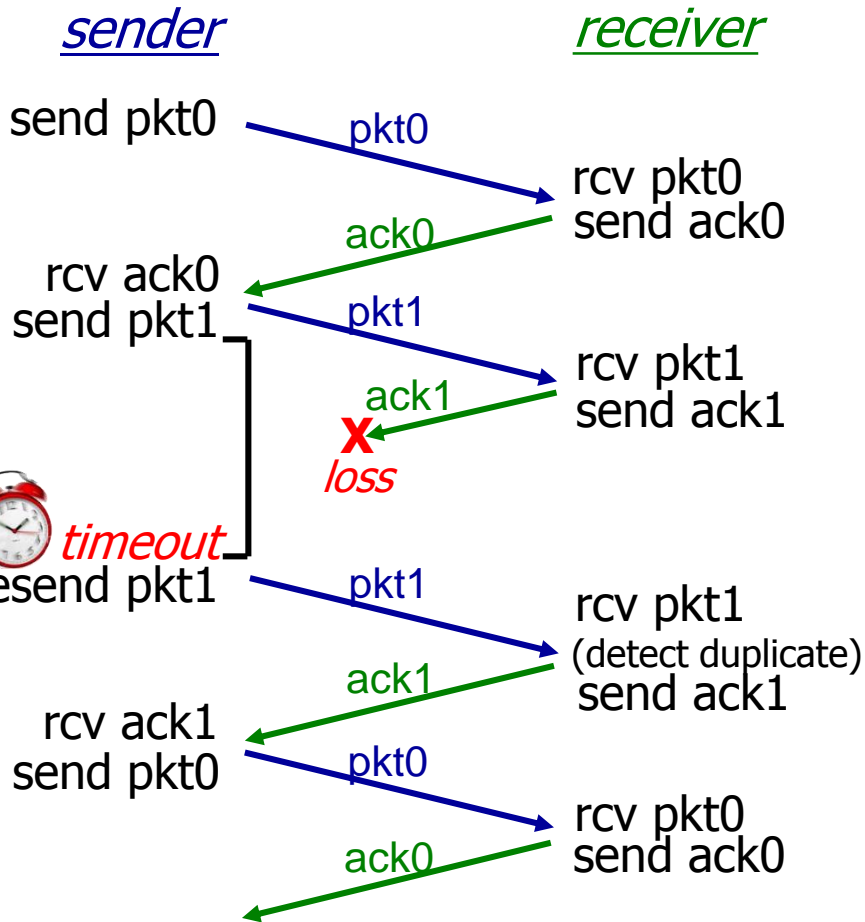

(c) ACK loss

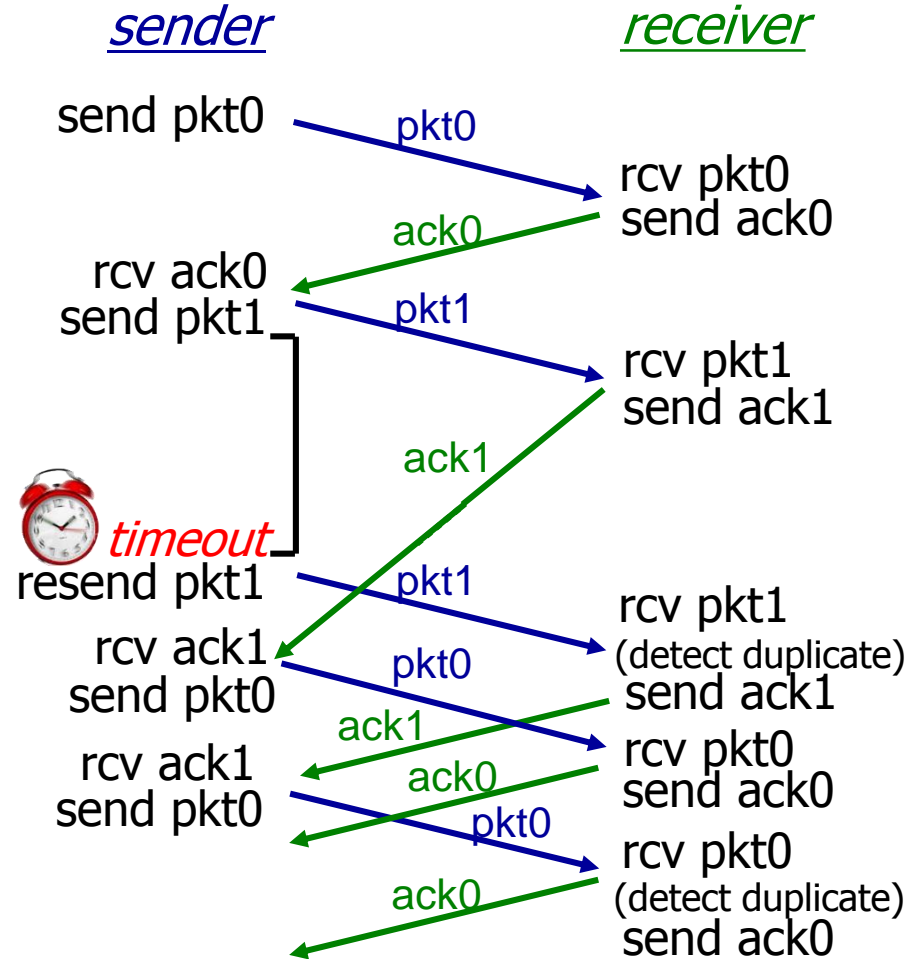

(d) premature timeout/ delayed ACK

# Performance of rdt3.0

- ❖ rdt3.0 is correct, but performance stinks
- ❖ e.g.: 1 Gbps link, 15 ms prop. delay, 8000 bit packet:

$$D_{trans} = \frac{L}{R} = \frac{8000 \text{ bits}}{10^9 \text{ bits/sec}} = 8 \text{ microseconds}$$

- $U_{sender}$ : *utilization* – fraction of time sender busy sending

$$U_{sender} = \frac{L/R}{RTT + L/R} = \frac{.008}{30.008} = 0.00027$$

- if RTT=30 msec, 1KB pkt every 30 msec: 33kB/sec thruput over 1 Gbps link
- ❖ network protocol limits use of physical resources!

# rdt3.0: stop-and-wait operation

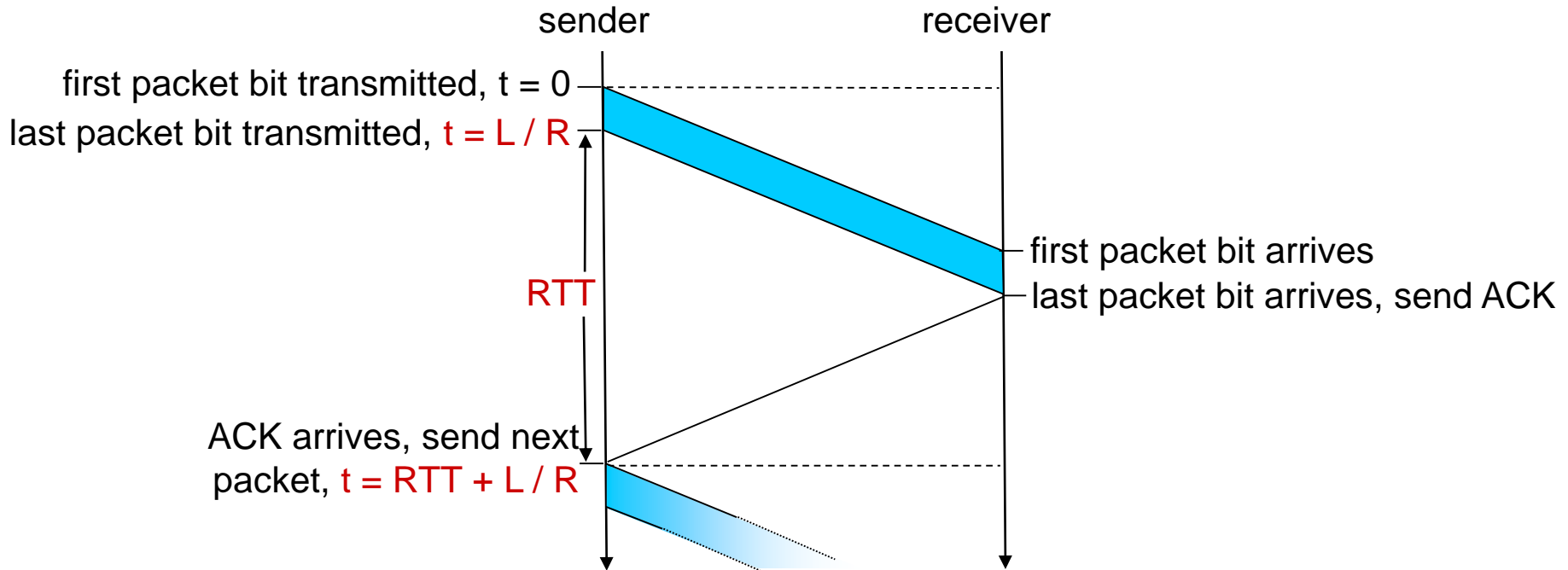

$$U_{\text{sender}} = \frac{L / R}{RTT + L / R} = \frac{.008}{30.008} = 0.00027$$

# Pipelined protocols

**pipelining:** sender allows multiple, “in-flight”, yet-to-be-acknowledged pkts

- range of sequence numbers must be increased
- buffering at sender and/or receiver

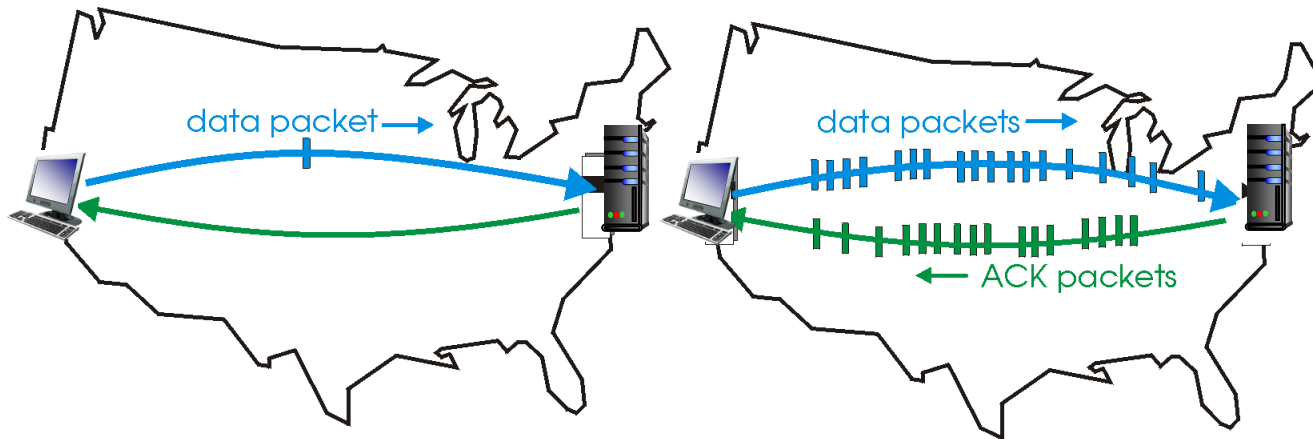

(a) a stop-and-wait protocol in operation

(b) a pipelined protocol in operation

❖ two generic forms of pipelined protocols: *go-Back-N*, *selective repeat*

# Pipelining: increased utilization

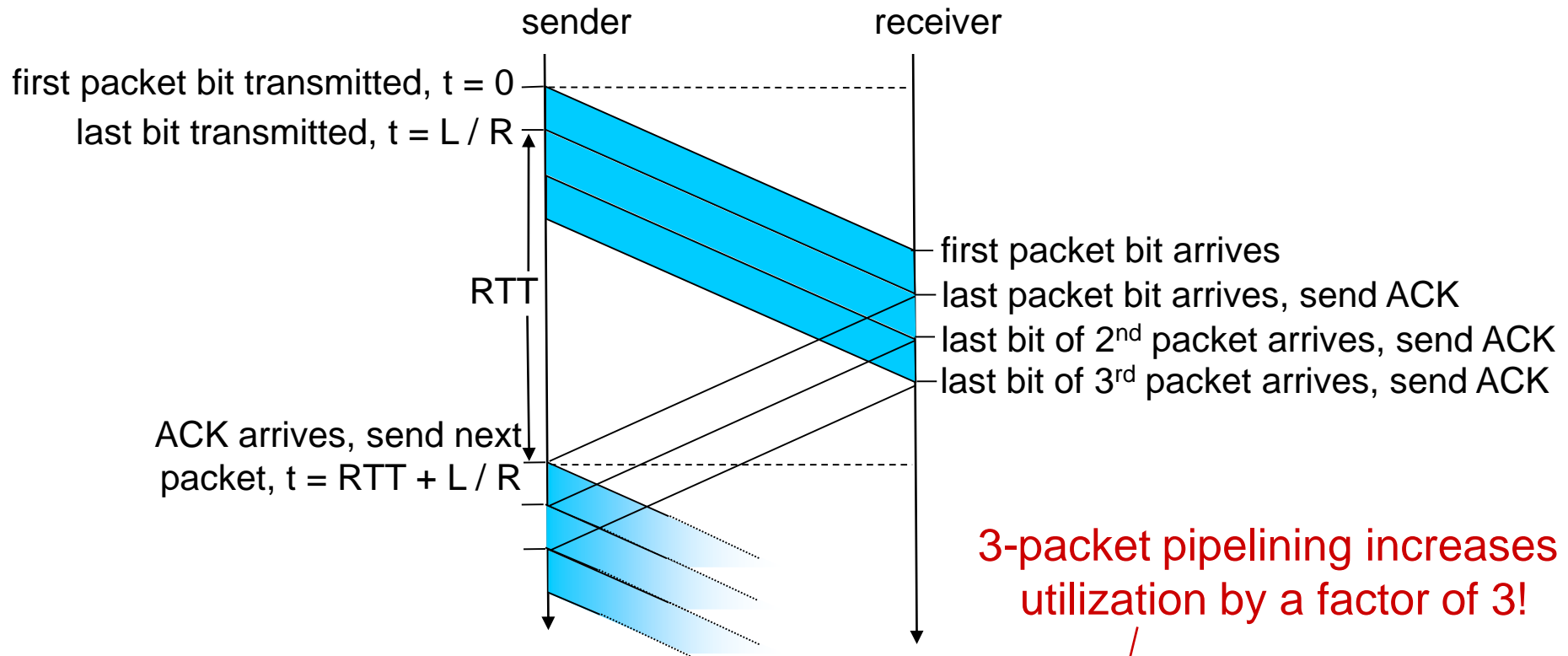

3-packet pipelining increases utilization by a factor of 3!

$$U_{\text{sender}} = \frac{3L / R}{RTT + L / R} = \frac{.0024}{30.008} = 0.00081$$

# Pipelined protocols: overview

## Go-back-N:

- ❖ sender can have up to N unacked packets in pipeline
- ❖ receiver only sends *cumulative ack*
  - doesn't ack packet if there's a gap
- ❖ *sender has timer for oldest unacked packet*
  - when timer expires, retransmit *all* unacked packets

## Selective Repeat:

- ❖ sender can have up to N unack'ed packets in pipeline
- ❖ rcvr sends *individual ack* for each packet
- ❖ sender maintains timer for each unacked packet
  - when timer expires, retransmit only that unacked packet

# Go-Back-N: sender

- ❖ k-bit seq # in pkt header
- ❖ “window” of up to N, consecutive unack’ed pkts allowed

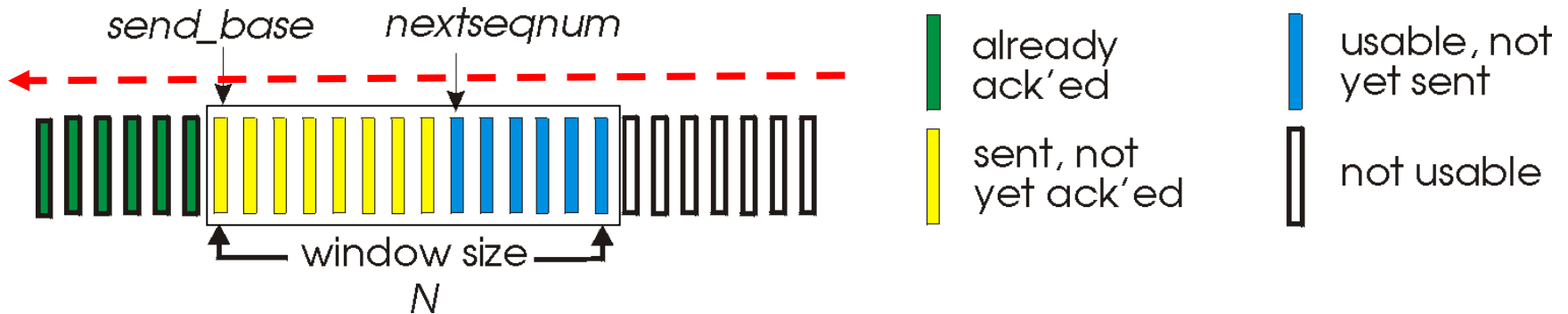

- ❖ ACK(n): ACKs all pkts up to, including seq # n - “cumulative ACK”
  - may receive duplicate ACKs (see receiver)
- ❖ timer for oldest in-flight pkt
- ❖ *timeout(n)*: retransmit packet n and all higher seq # pkts in window

# GBN: sender extended FSM (finite state machine)

Making sure there is nothing in the PIPE

```

rdt_send(data)
-----
if (nextseqnum < base+N) {
    sndpkt[nextseqnum] = make_pkt(nextseqnum,data,chksum)
    udt_send(sndpkt[nextseqnum])
    if (base == nextseqnum)
        start_timer
    nextseqnum++
}
else
    refuse_data(data)
    
```

$\Lambda$   
 -----  
 base=1  
 nextseqnum=1

rdt\_rcv(rcvpkt) && corrupt(rcvpkt)

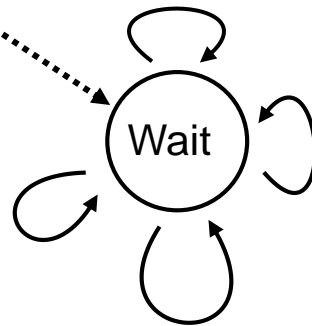

```

timeout
-----
start_timer
udt_send(sndpkt[base])
udt_send(sndpkt[base+1])
...
udt_send(sndpkt[nextseqnum-1])
    
```

rdt\_rcv(rcvpkt) && notcorrupt(rcvpkt)

```

base = getacknum(rcvpkt)+1
If (base == nextseqnum)
    stop_timer
else
    start_timer
    
```

NEXT ...

# GBN: receiver extended FSM

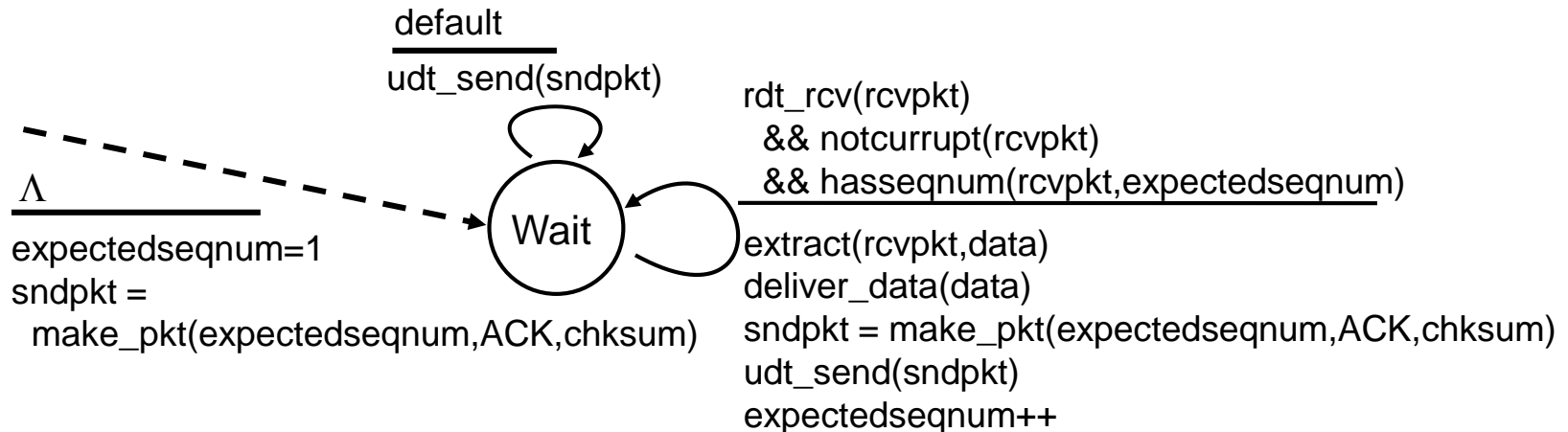

ACK-only: always send ACK for correctly-received pkt with highest *in-order* seq #

- may generate duplicate ACKs
- need only remember **expectedseqnum**
- ❖ out-of-order pkt:
  - discard (don't buffer): **no receiver buffering!**
  - re-ACK pkt with highest in-order seq #

# GBN in action

sender window (N=4)

0 1 2 3 4 5 6 7 8  
 0 1 2 3 4 5 6 7 8  
 0 1 2 3 4 5 6 7 8  
 0 1 2 3 4 5 6 7 8

0 1 2 3 4 5 6 7 8  
 0 1 2 3 4 5 6 7 8

0 1 2 3 4 5 6 7 8  
 0 1 2 3 4 5 6 7 8  
 0 1 2 3 4 5 6 7 8  
 0 1 2 3 4 5 6 7 8

sender

send pkt0  
 send pkt1  
 send pkt2  
 send pkt3  
 (wait)

rcv ack0, send pkt4  
 rcv ack1, send pkt5

ignore duplicate ACK



*pkt 2 timeout*

send pkt2  
 send pkt3  
 send pkt4  
 send pkt5

receiver

receive pkt0, send ack0  
 receive pkt1, send ack1

receive pkt3, discard,  
 (re)send ack1

receive pkt4, discard,  
 (re)send ack1

receive pkt5, discard,  
 (re)send ack1

rcv pkt2, deliver, send ack2  
 rcv pkt3, deliver, send ack3  
 rcv pkt4, deliver, send ack4  
 rcv pkt5, deliver, send ack5

*X loss*

# Selective repeat

- ❖ receiver *individually* acknowledges all correctly received pkts
  - buffers pkts, as needed, for eventual in-order delivery to upper layer
- ❖ sender only resends pkts for which ACK not received
  - sender timer for each unACKed pkt
- ❖ sender window
  - $N$  consecutive seq #'s
  - limits seq #'s of sent, unACKed pkts

# Selective repeat: sender, receiver windows

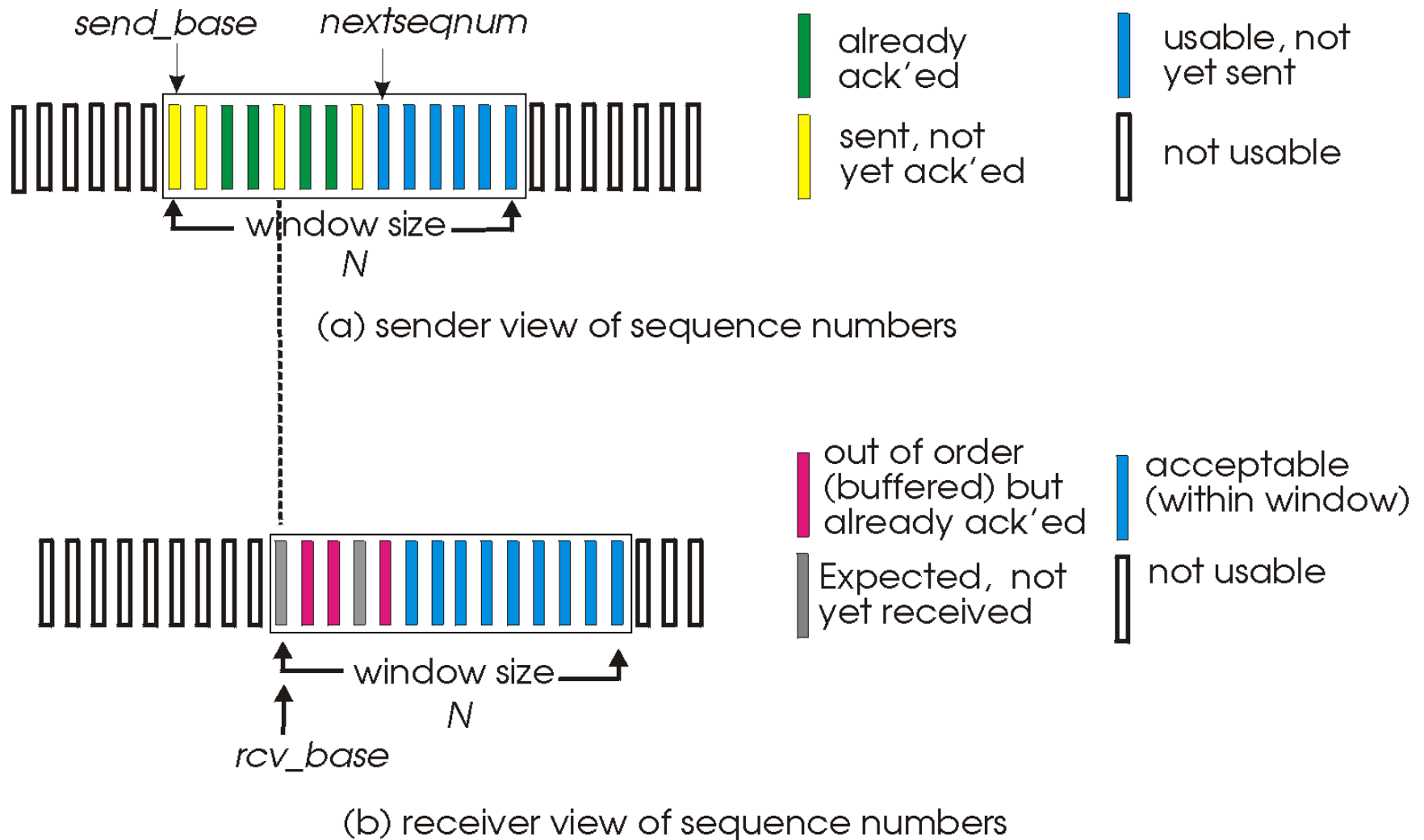

# Selective repeat

## sender

### data from above:

- ❖ if next available seq # in window, send pkt

### timeout(n):

- ❖ resend pkt n, restart timer

### ACK(n) in [sendbase,sendbase+N]:

- ❖ mark pkt n as received
- ❖ if n smallest unACKed pkt, advance window base to next unACKed seq #

## receiver

### pkt n in [rcvbase,rcvbase+N-1]

- ❖ send ACK(n)
- ❖ out-of-order: buffer
- ❖ in-order: deliver (also deliver buffered, in-order pkts), advance window to next not-yet-received pkt

### pkt n in [rcvbase-N,rcvbase-1]

- ❖ ACK(n)

### otherwise:

- ❖ ignore

# Selective repeat in action

window size = 4

sender window (N=4)

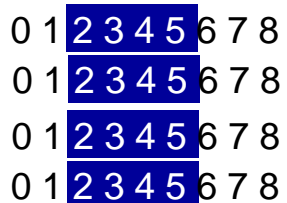
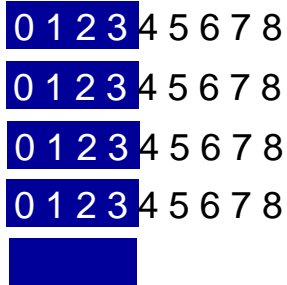

sender

send pkt0  
send pkt1  
send pkt2  
send pkt3  
(wait)

rcv ack0, send pkt4  
rcv ack1, send pkt5

record ack3 arrived



*pkt 2 timeout*

send pkt2

record ack4 arrived

record ack4 arrived

receiver

receive pkt0, send ack0  
receive pkt1, send ack1

receive pkt3, **buffer**,  
send ack3

receive pkt4, **buffer**,  
send ack4

receive pkt5, **buffer**,  
send ack5

rcv pkt2; deliver pkt2,  
pkt3, pkt4, pkt5; send ack2

*Q: what happens when ack2 arrives?*

# Selective repeat: dilemma

example:

- ❖ seq #'s: 0, 1, 2, 3
- ❖ window size=3
- ❖ receiver sees no difference in two scenarios!
- ❖ duplicate data accepted as new in (b) .. **BECAUSE Rx doesn't know about LOST NAKs.**

Q: what relationship between seq # size and window size to avoid problem in (b)?

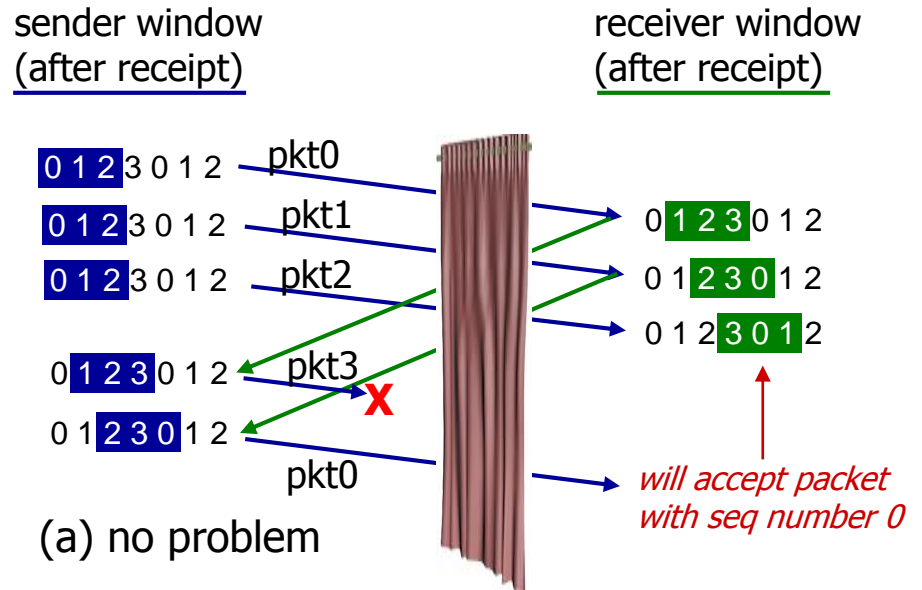

receiver can't see sender side.  
 receiver behavior identical in both cases!  
*something's (very) wrong!*

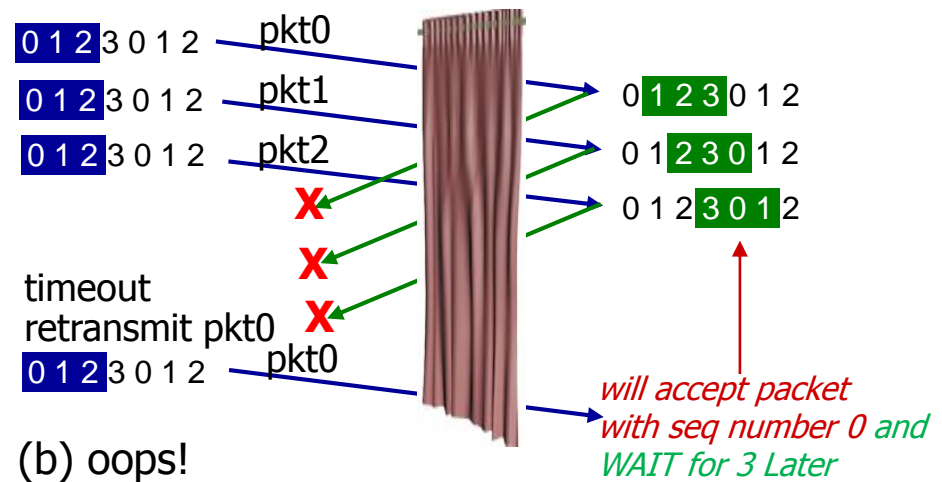

# Chapter 3 outline

3.1 transport-layer services

3.2 multiplexing and demultiplexing

3.3 connectionless transport: UDP

3.4 principles of reliable data transfer

3.5 connection-oriented transport: TCP

- segment structure
- reliable data transfer
- flow control
- connection management

3.6 principles of congestion control

3.7 TCP congestion control

- ❖ **point-to-point:**
  - one sender, one receiver
- ❖ **reliable, in-order *byte stream*:**
  - no “message boundaries”
- ❖ **pipelined:**
  - TCP congestion and flow control set window size
- ❖ **full duplex data:**
  - bi-directional data flow in same connection
  - MSS: maximum segment size
- ❖ **connection-oriented:**
  - handshaking (exchange of control msgs) inits sender, receiver state before data exchange
- ❖ **flow controlled:**
  - sender will not overwhelm receiver

# TCP segment structure

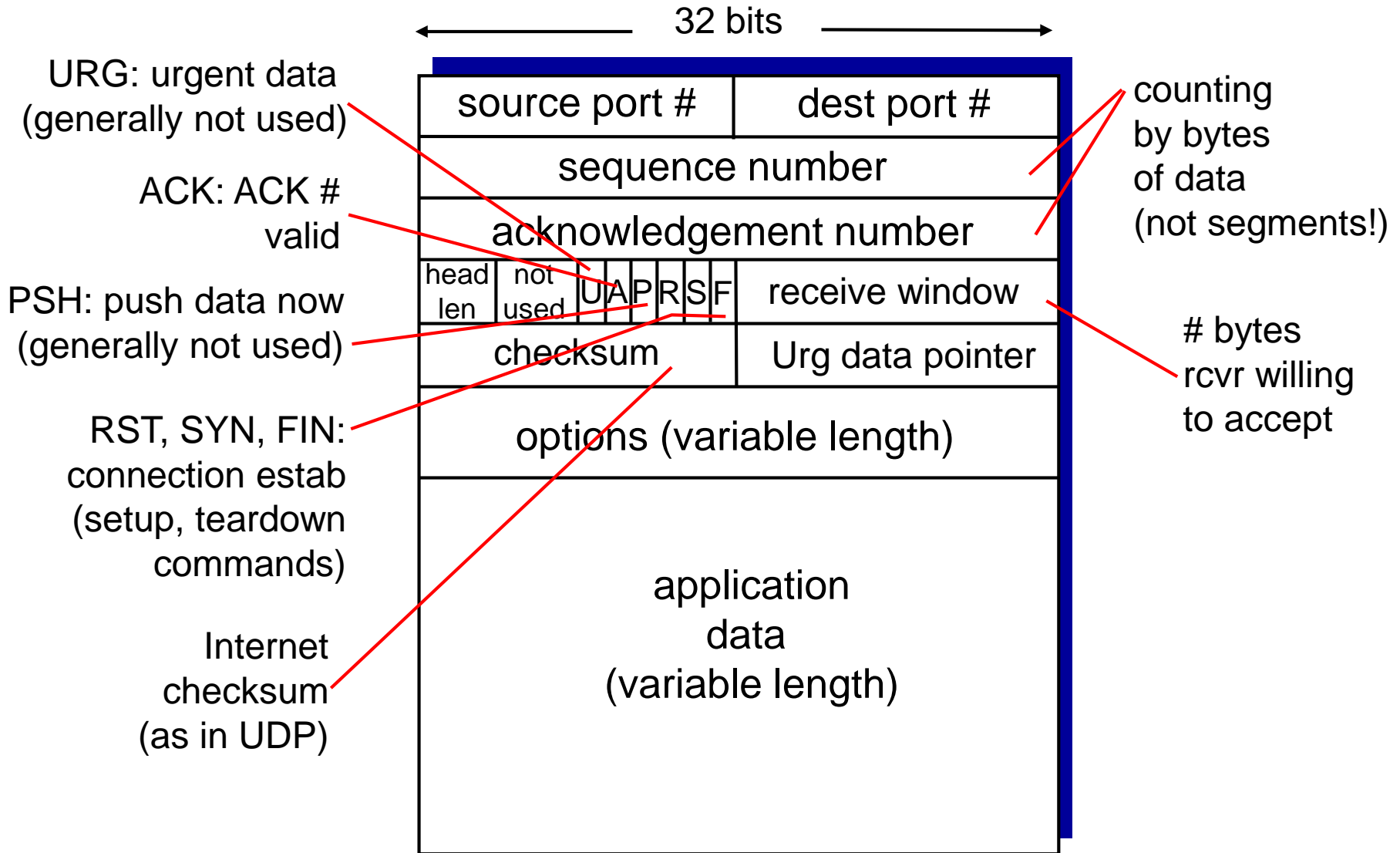

# TCP seq. numbers, ACKs

## sequence numbers:

- byte stream “number” of first byte in segment’s data

## acknowledgements:

- seq # of next byte expected from other side
- cumulative ACK

**Q:** how receiver handles out-of-order segments

- A:** TCP spec doesn’t say, - up to implementor

outgoing segment from sender

source port #		dest port #	
sequence number			
acknowledgement number			
		rwnd	
checksum		urg pointer	

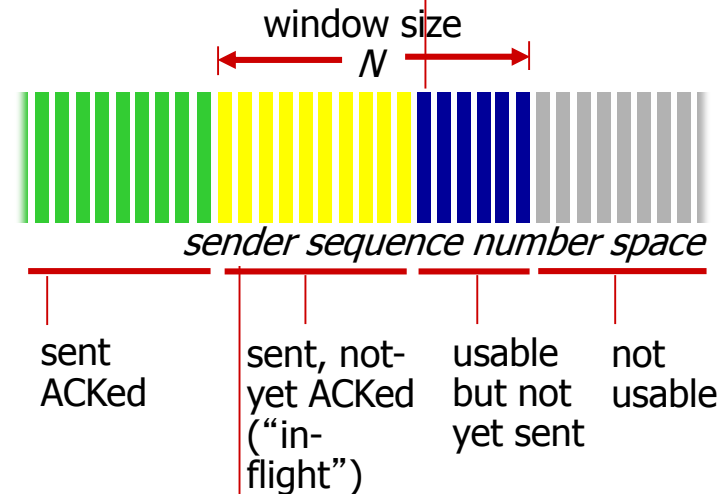

incoming segment to sender

source port #		dest port #	
sequence number			
acknowledgement number			
		A	
checksum		urg pointer	

# TCP seq. numbers, ACKs

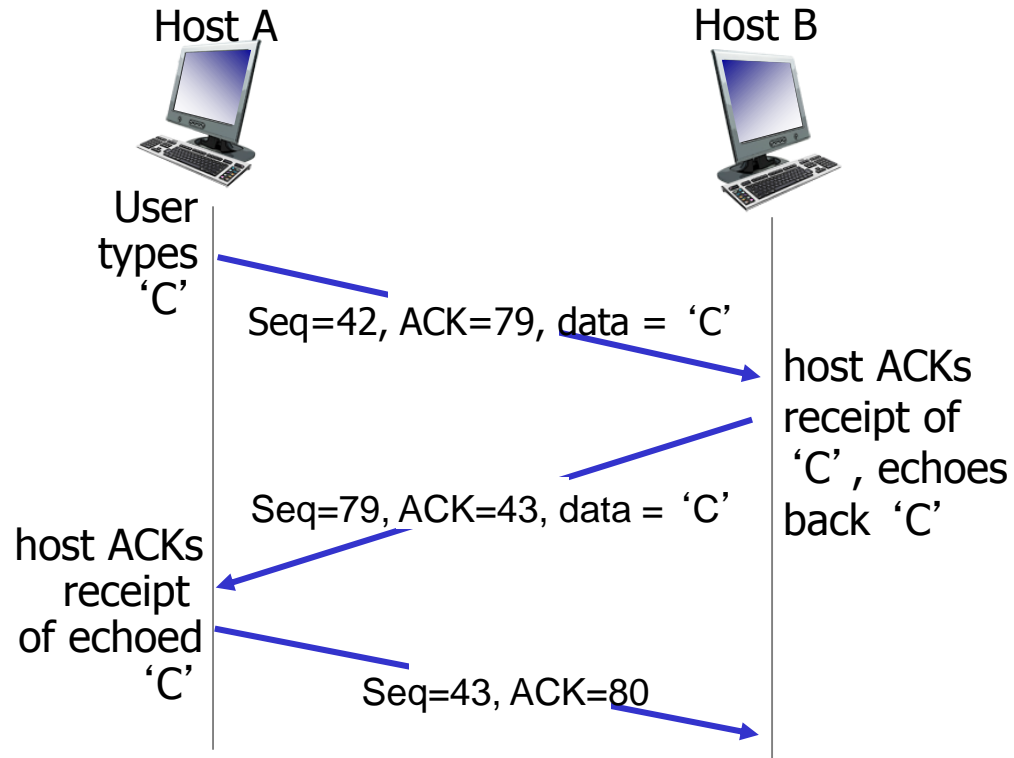

simple telnet scenario

# TCP round trip time, timeout

Q: how to set TCP timeout value?

- ❖ longer than RTT
  - but RTT varies
- ❖ too short: premature timeout, unnecessary retransmissions
- ❖ too long: slow reaction to segment loss

Q: how to estimate RTT?

- ❖ **SampleRTT**: measured time from segment transmission until ACK receipt
  - ignore retransmissions
- ❖ **SampleRTT** will vary, want estimated RTT “smoother”
  - average several *recent* measurements, not just current **SampleRTT**

# TCP round trip time, timeout

$$\text{EstimatedRTT} = (1 - \alpha) * \text{EstimatedRTT} + \alpha * \text{SampleRTT}$$

- ❖ exponential weighted moving average
- ❖ influence of past sample decreases exponentially fast
- ❖ typical value:  $\alpha = 0.125$  (RFC - 2119)

$\alpha$  is constant weighting factor ( $0 \leq \alpha < 1$ )

smoothing factor; determines weight given to previous estimate

What if  $\alpha = 0, 1$

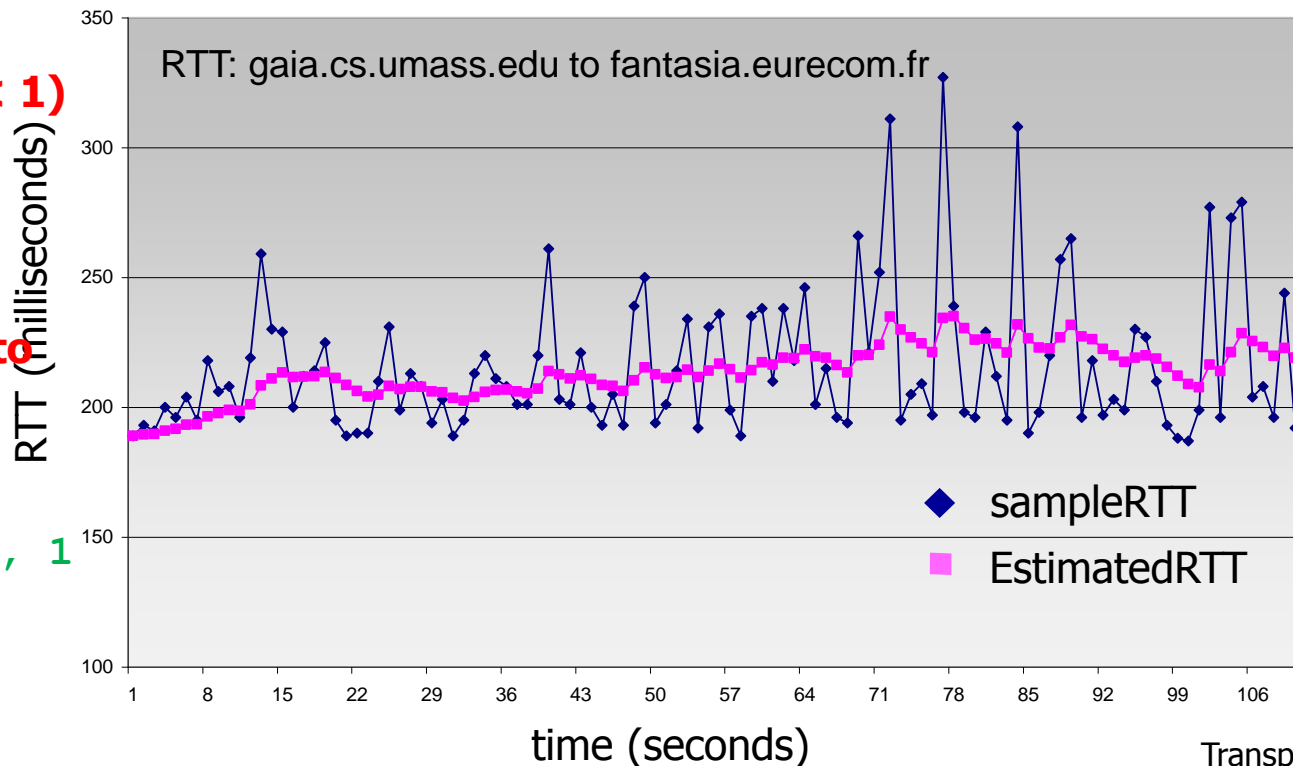

# TCP round trip time, timeout

- ❖ **timeout interval: EstimatedRTT plus “safety margin”**
  - large variation in **EstimatedRTT** -> larger safety margin
- ❖ estimate **SampleRTT** deviation from **EstimatedRTT**: (**RFC 6298**)

$$\text{DevRTT} = (1-\beta) * \text{DevRTT} + \beta * |\text{SampleRTT} - \text{EstimatedRTT}|$$

(typically,  $\beta = 0.25$ )

RTT Variation: as an estimate of how much **SampleRTT** typically deviates from **EstimatedRTT**:

$$\text{TimeoutInterval} = \text{EstimatedRTT} + 4 * \text{DevRTT}$$



↑  
estimated RTT

↑  
“safety margin”

# TCP reliable data transfer

- ❖ TCP creates rdt service on top of IP' s unreliable service
  - pipelined segments
  - cumulative acks
  - single retransmission timer
- ❖ retransmissions triggered by:
  - timeout events
  - duplicate acks

let' s initially consider simplified TCP sender:

- ignore duplicate acks
- ignore flow control, congestion control

# TCP sender events:

## *data rcvd from app:*

- ❖ create segment with seq #
- ❖ seq # is byte-stream number of first data byte in segment
- ❖ start timer if not already running
  - think of timer as for oldest unacked segment
  - expiration interval: `TimeOutInterval`

## *timeout:*

- ❖ retransmit segment that caused timeout
- ❖ restart timer

## *ack rcvd:*

- ❖ if ack acknowledges previously unacked segments
  - update what is known to be ACKed
  - start timer if there are still unacked segments

# TCP sender (simplified)

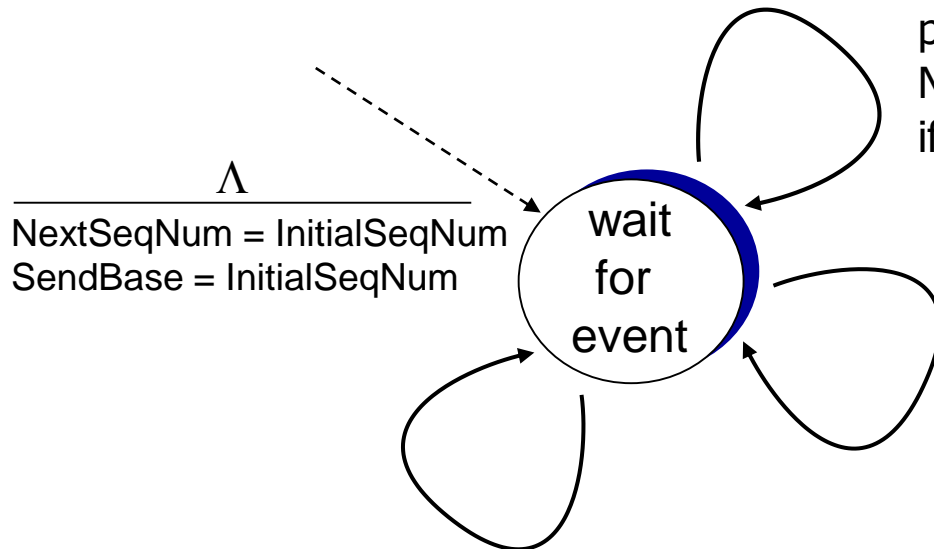

$\Lambda$   
NextSeqNum = InitialSeqNum  
SendBase = InitialSeqNum

data received from application above

create segment, seq. #: NextSeqNum  
pass segment to IP (i.e., “send”)  
NextSeqNum = NextSeqNum + length(data)  
if (timer currently not running)  
start timer

timeout

retransmit not-yet-acked segment  
with smallest seq. #  
start timer

ACK received, with ACK field value  $y$

```
if (y > SendBase) {  
    SendBase = y  
    /* SendBase-1: last cumulatively ACKed byte */  
    if (there are currently not-yet-acked segments)  
        start timer  
    else stop timer  
}
```

# TCP: retransmission scenarios

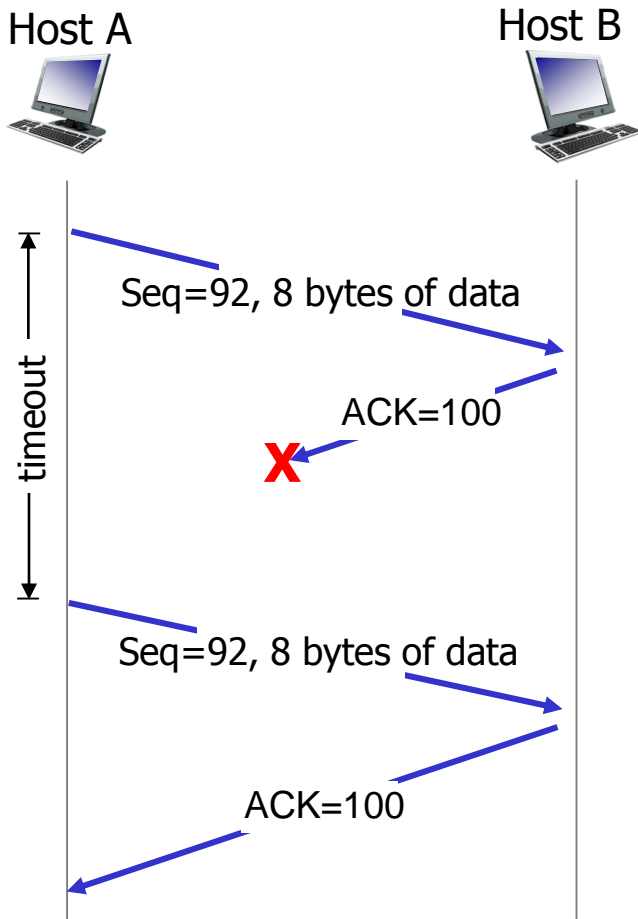

lost ACK scenario

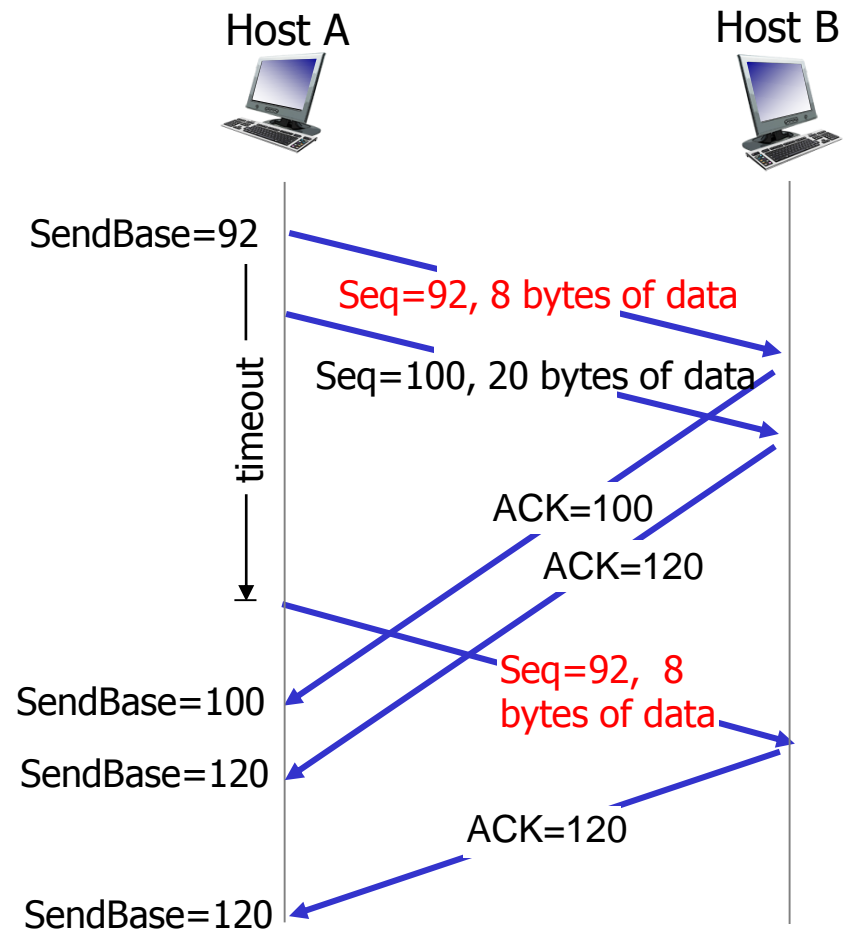

premature timeout

# TCP: retransmission scenarios

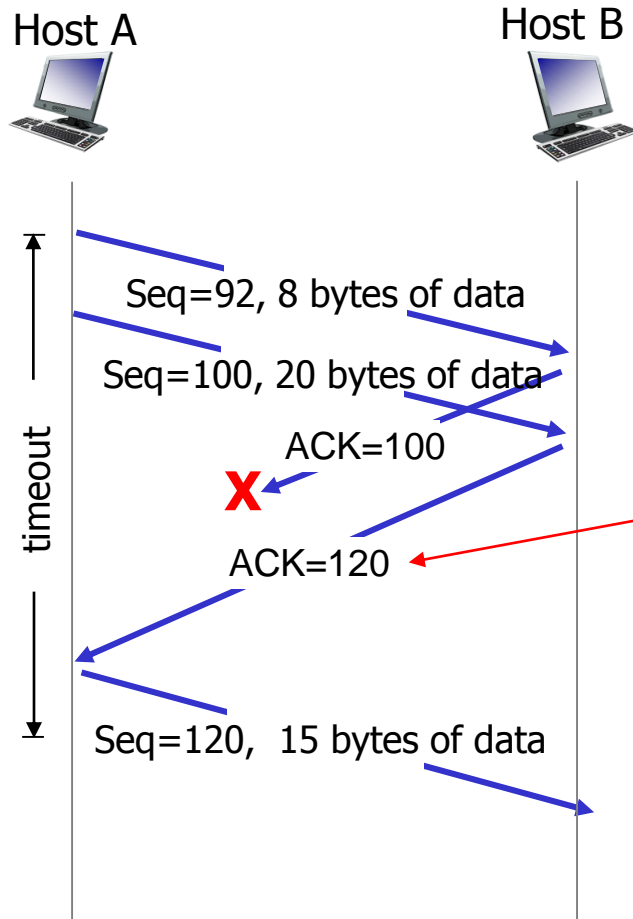

A cumulative acknowledgment avoids retransmission of the first segment

cumulative ACK

# TCP ACK generation [RFC 1122, RFC 2581]

<i>event at receiver</i>	<i>TCP receiver action</i>
arrival of in-order segment with expected seq #. All data up to expected seq # already ACKed	delayed ACK. Wait up to 500ms for next segment. If no next segment, send ACK
arrival of in-order segment with expected seq #. One other segment has ACK pending	immediately send single cumulative ACK, ACKing both in-order segments
arrival of out-of-order segment higher-than-expected seq. # . Gap detected	immediately send <i>duplicate ACK</i> , indicating seq. # of next expected byte
arrival of segment that partially or completely fills gap	immediate send ACK, provided that segment starts at lower end of gap

# TCP fast retransmit

- ❖ time-out period often relatively long:
  - long delay before resending lost packet
- ❖ detect lost segments via duplicate ACKs.
  - sender often sends many segments back-to-back
  - if segment is lost, there will likely be many duplicate ACKs.

## *TCP fast retransmit*

- if sender receives 3 ACKs for same data (“triple duplicate ACKs”), resend unacked segment with smallest seq #
- likely that unacked segment lost, so don't wait for timeout

# TCP fast retransmit

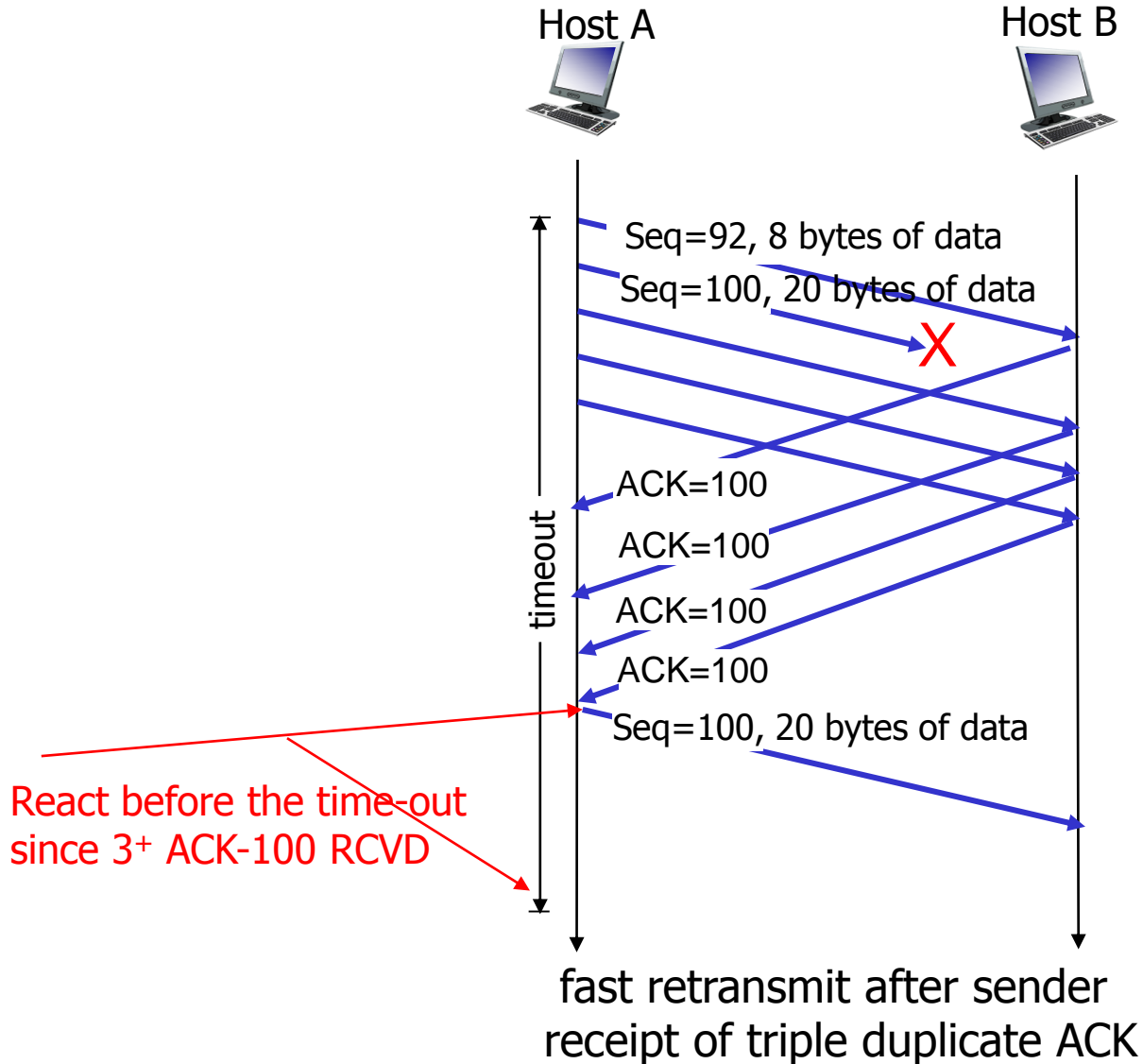



# TCP flow control

- ❖ receiver “advertises” free buffer space by including **rwnd** (**receiver window**) value in TCP header of *receiver-to-sender segments*.
  - **RcvBuffer** size set via socket options (typical default is 4096 bytes)
  - many operating systems autoadjust **RcvBuffer**
- ❖ sender limits amount of unacked (“in-flight”) data to receiver’s **rwnd** value
- ❖ guarantees receive buffer will not overflow

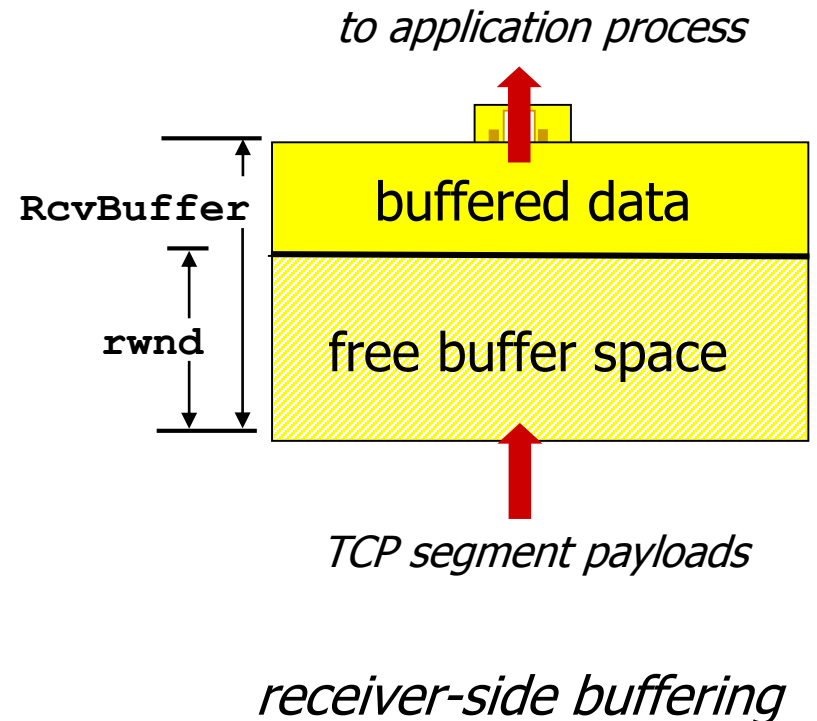

# Connection Management

before exchanging data, sender/receiver “handshake”:

- ❖ agree to establish connection (each knowing the other willing to establish connection)
- ❖ agree on connection parameters

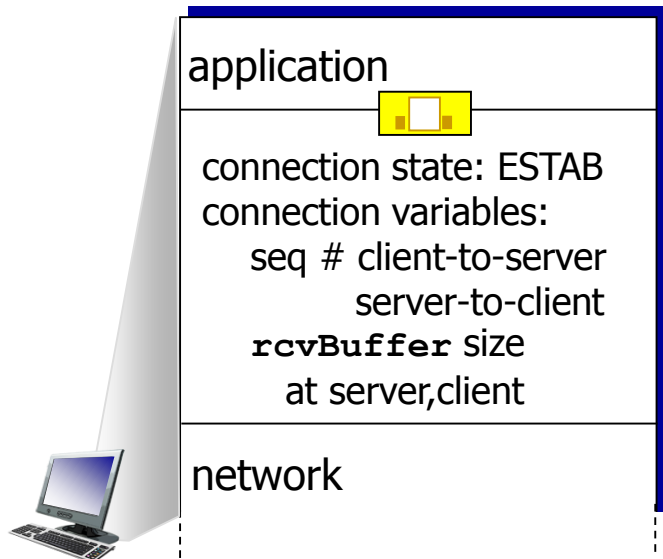

```
Socket clientSocket =  
    newSocket("hostname", "port  
    number");
```

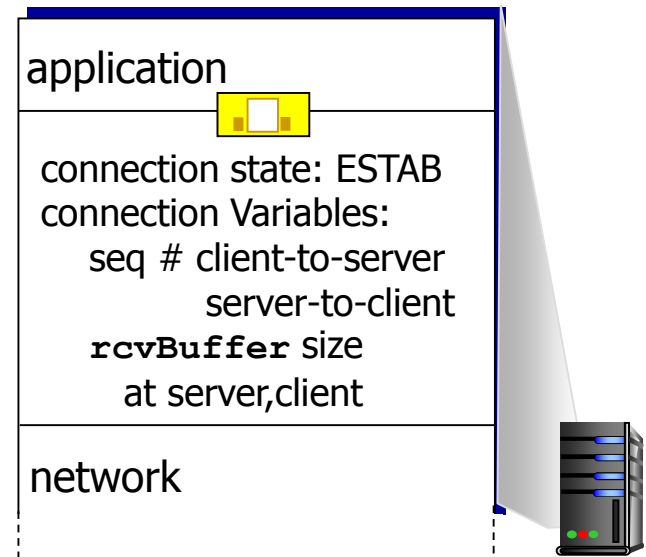

```
Socket connectionSocket =  
    welcomeSocket.accept();
```

# Agreeing to establish a connection

2-way handshake:

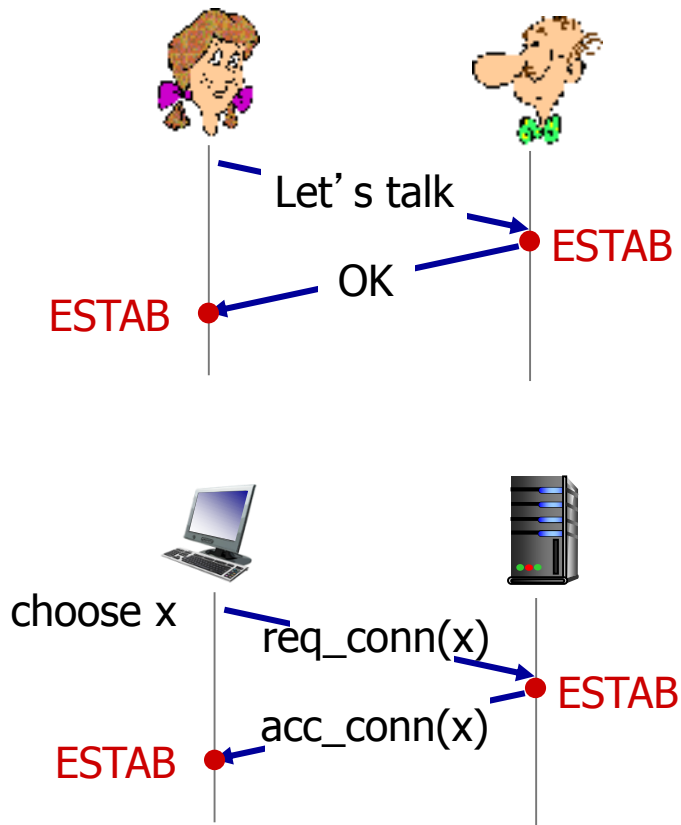

**Q:** will 2-way handshake always work in network?

- ❖ variable delays
- ❖ retransmitted messages (e.g. req\_conn(x)) due to message loss
- ❖ message reordering
- ❖ can't "see" other side



# TCP 3-way handshake

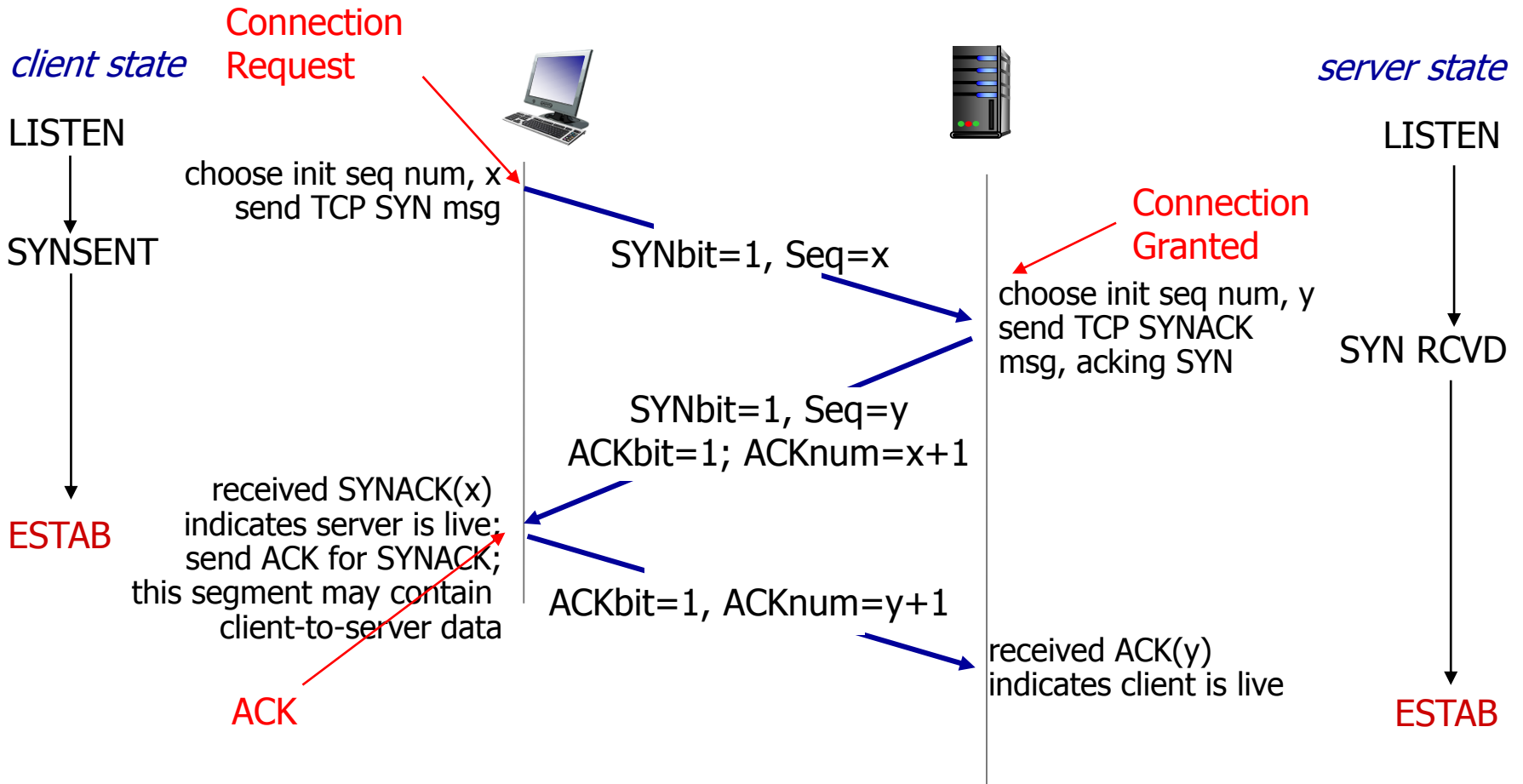

# TCP 3-way handshake: FSM

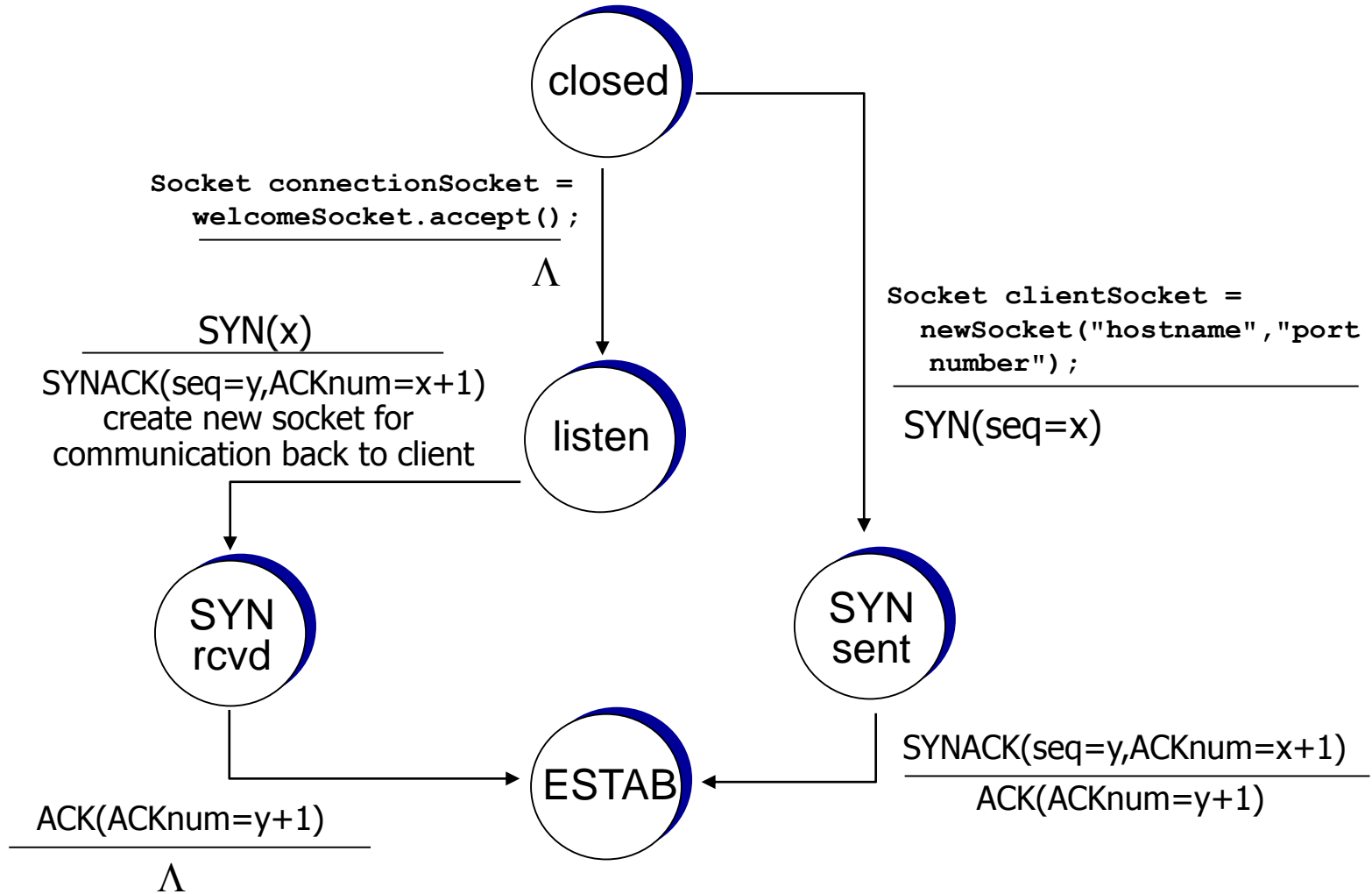

# TCP: closing a connection

- ❖ client, server each close their side of connection
  - send TCP segment with FIN bit = 1
- ❖ respond to received FIN with ACK
  - on receiving FIN, ACK can be combined with own FIN
- ❖ simultaneous FIN exchanges can be handled

# TCP: closing a connection

*client state*

ESTAB

`clientSocket.close()`

FIN\_WAIT\_1

can no longer  
send but can  
receive data

FIN\_WAIT\_2

wait for server  
close

TIMED\_WAIT

timed wait  
for  $2 * \text{max}$   
segment lifetime

CLOSED



FINbit=1, seq=x

ACKbit=1; ACKnum=x+1

FINbit=1, seq=y

ACKbit=1; ACKnum=y+1

can still  
send data

can no longer  
send data

*server state*

ESTAB

CLOSE\_WAIT

LAST\_ACK

CLOSED

# Principles of congestion control

## *congestion:*

- ❖ informally: “too many sources sending too much data too fast for *network* to handle”
- ❖ different from flow control!
- ❖ manifestations:
  - lost packets (buffer overflow at routers)
  - long delays (queueing in router buffers)
- ❖ a top-10 problem!

# Causes/costs of congestion: scenario I

- ❖ two senders, two receivers
- ❖ one router, infinite buffers
- ❖ output link capacity:  $R$
- ❖ no retransmission

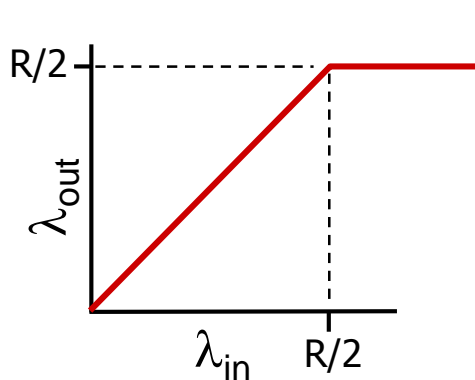
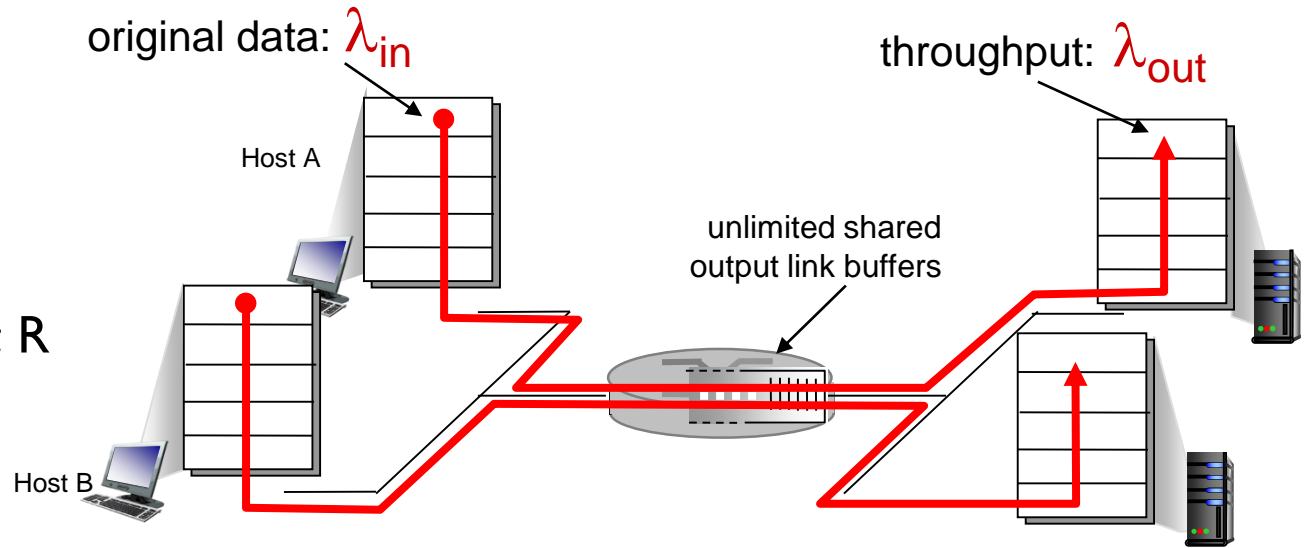

- ❖ maximum per-connection throughput:  $R/2$

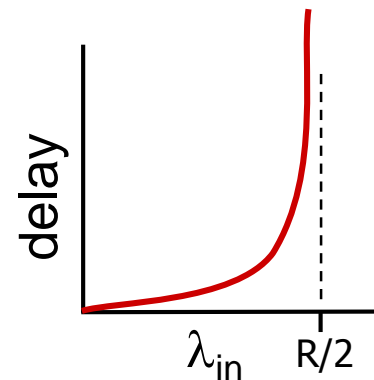

- ❖ large delays as arrival rate,  $\lambda_{in}$ , approaches capacity

# Causes/costs of congestion: scenario 2

- ❖ one router, *finite* buffers
- ❖ sender retransmission of timed-out packet
  - application-layer input = application-layer output:  $\lambda_{in} = \lambda_{out}$
  - transport-layer input includes *retransmissions* :  $\lambda'_{in} \geq \lambda_{in}$

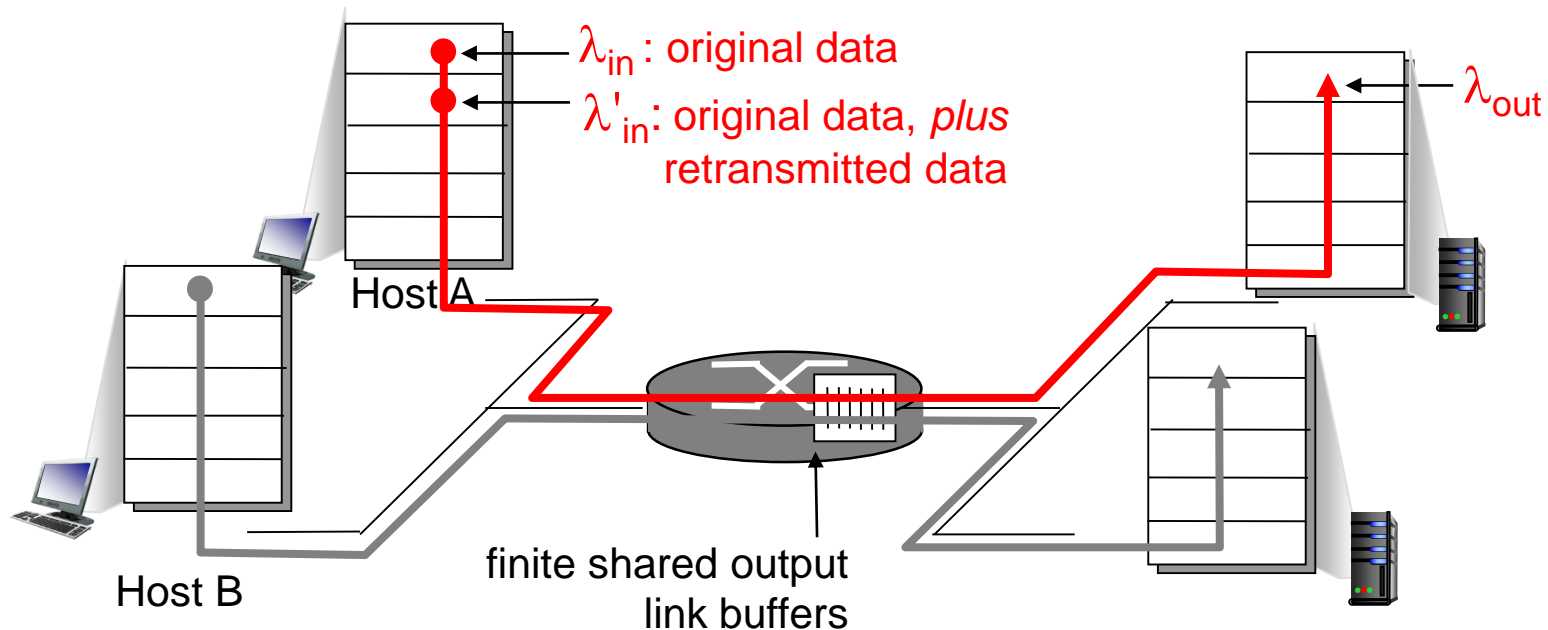

# Causes/costs of congestion: scenario 2

idealization: perfect knowledge

- ❖ sender sends only when router buffers available

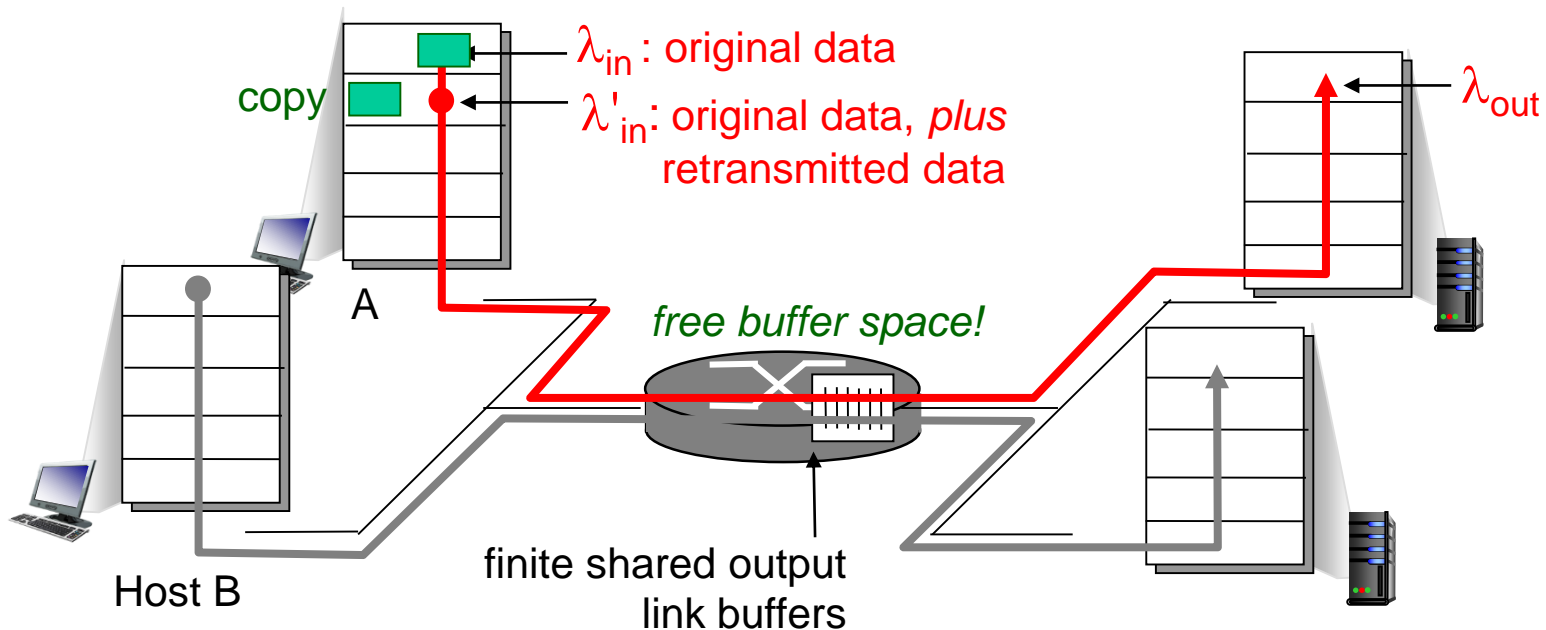
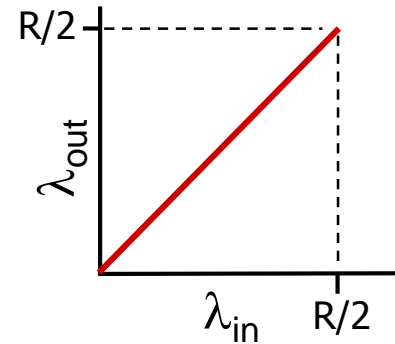

# Causes/costs of congestion: scenario 2

## *Idealization: known loss*

packets can be lost,  
dropped at router due  
to full buffers

- ❖ sender only resends if  
packet *known* to be lost

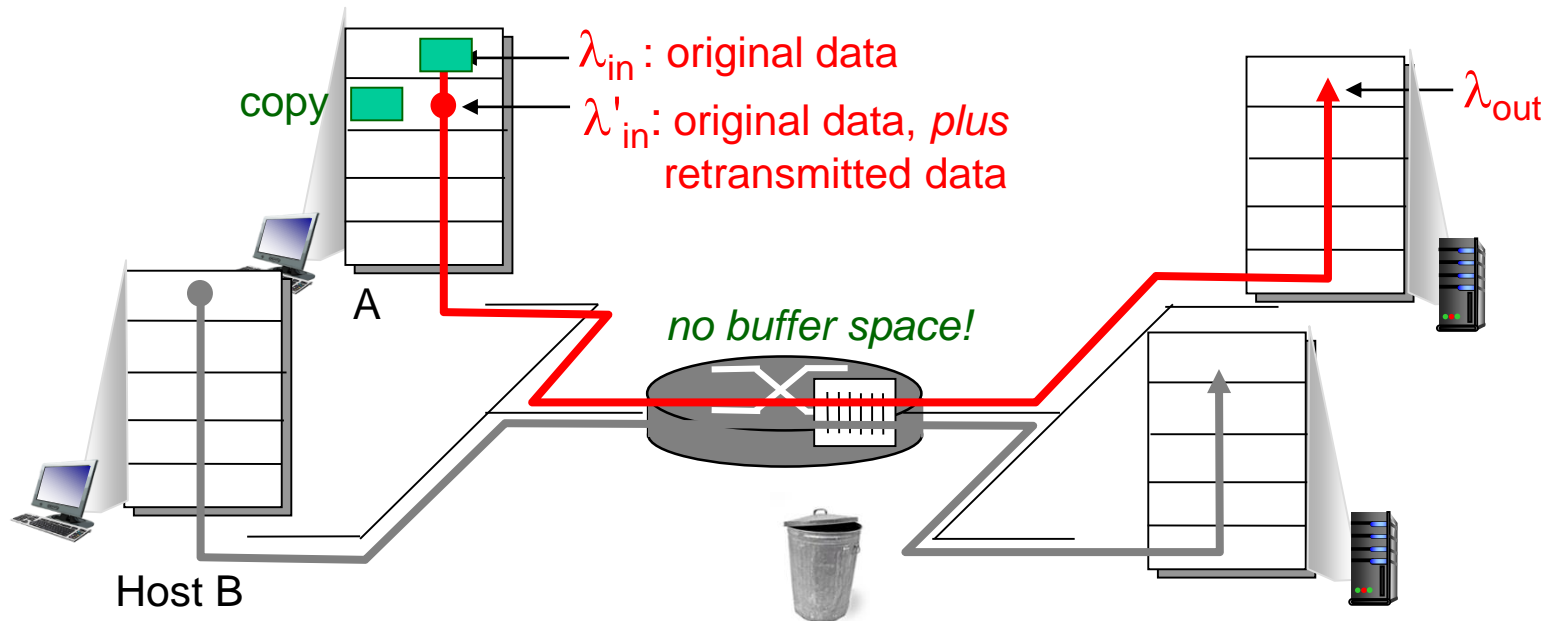

# Causes/costs of congestion: scenario 2

## Idealization: *known loss*

packets can be lost, dropped at router due to full buffers

- ❖ sender only resends if packet *known* to be lost

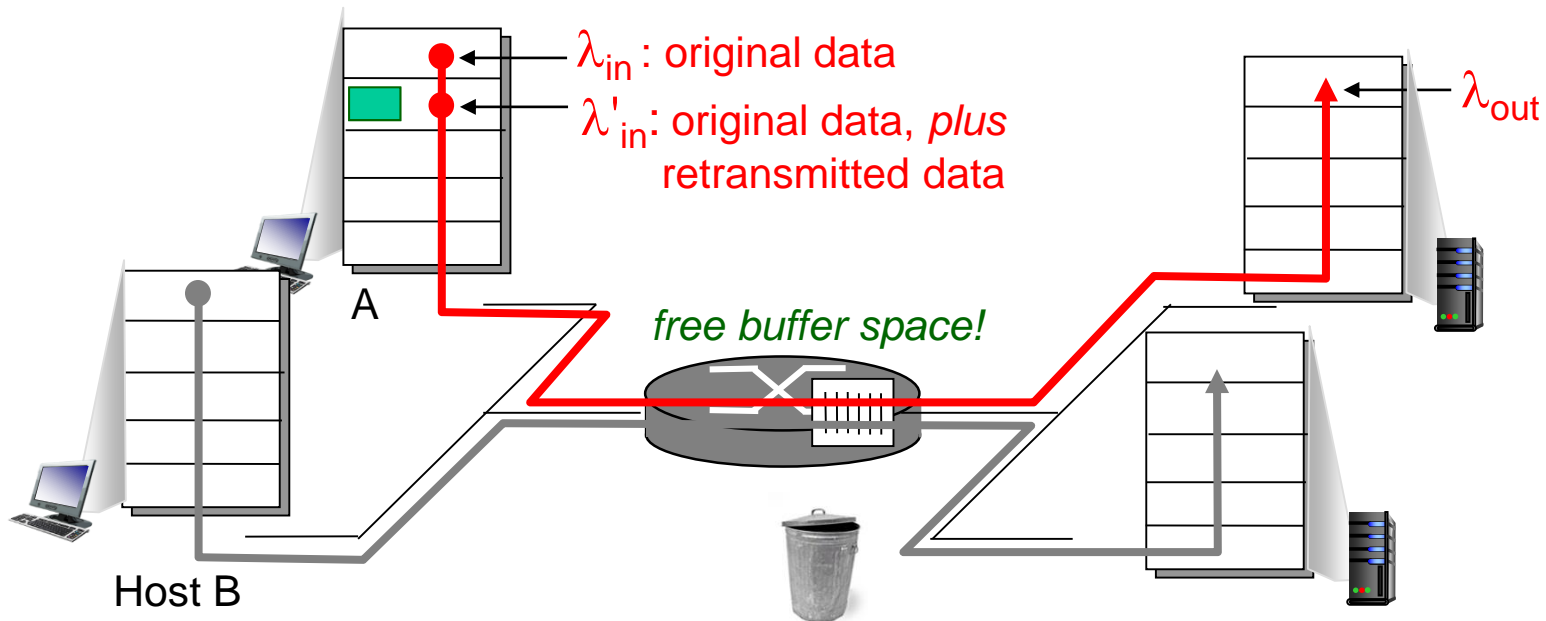
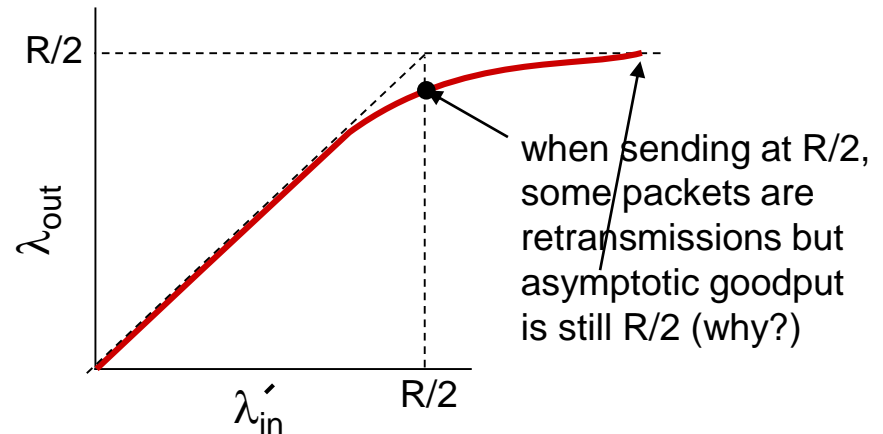

# Causes/costs of congestion: scenario 2

## Realistic: *duplicates*

- ❖ packets can be lost, dropped at router due to full buffers
- ❖ sender times out prematurely, sending *two* copies, both of which are delivered

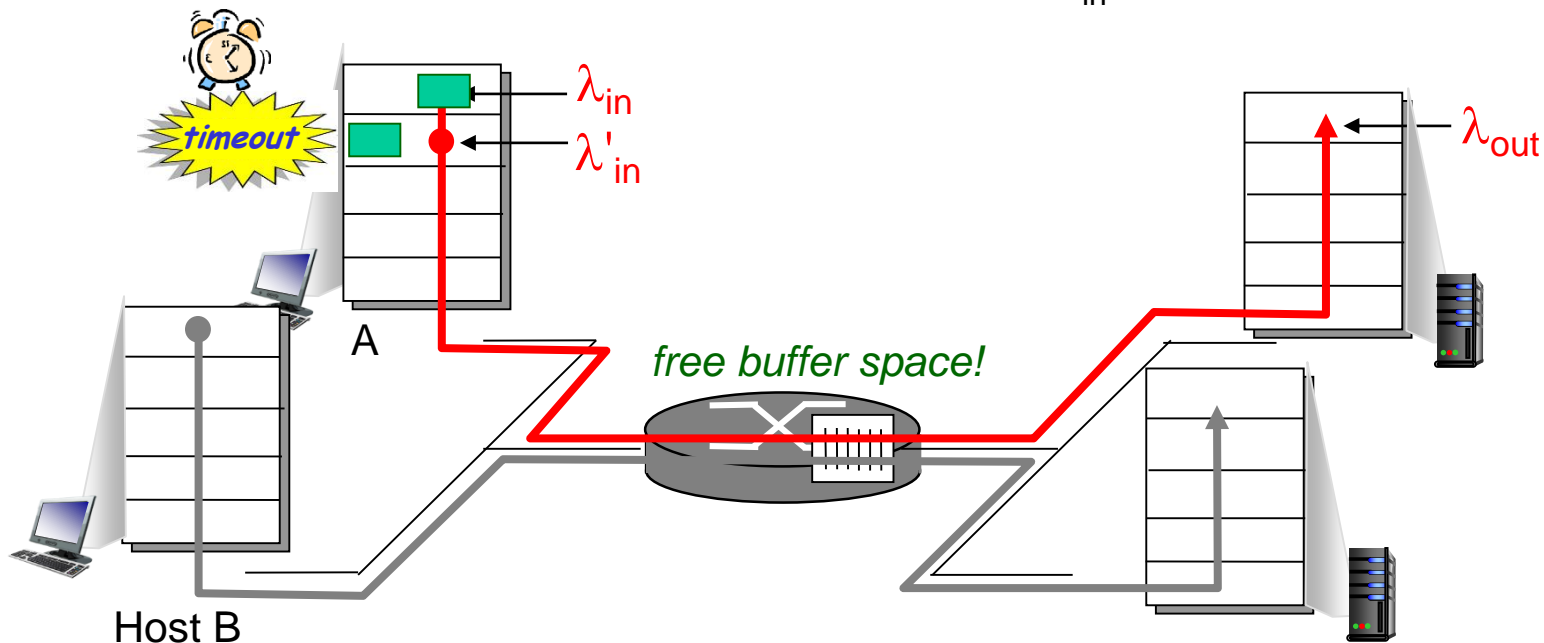
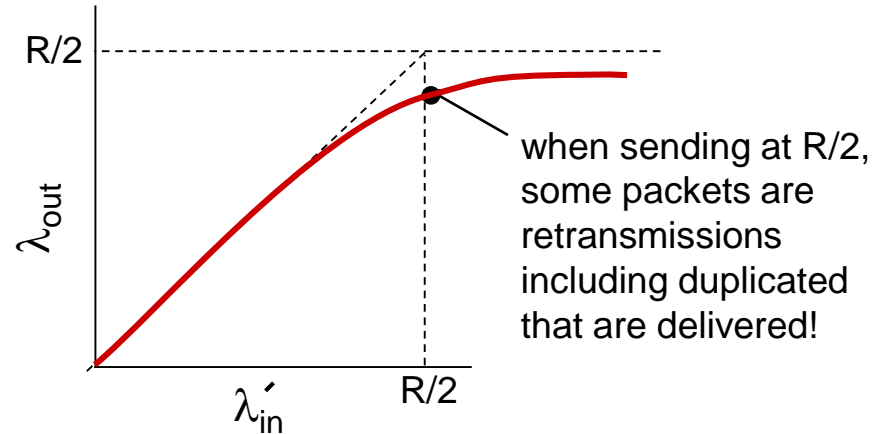

# Causes/costs of congestion: scenario 2

## Realistic: *duplicates*

- ❖ packets can be lost, dropped at router due to full buffers
- ❖ sender times out prematurely, sending *two* copies, both of which are delivered

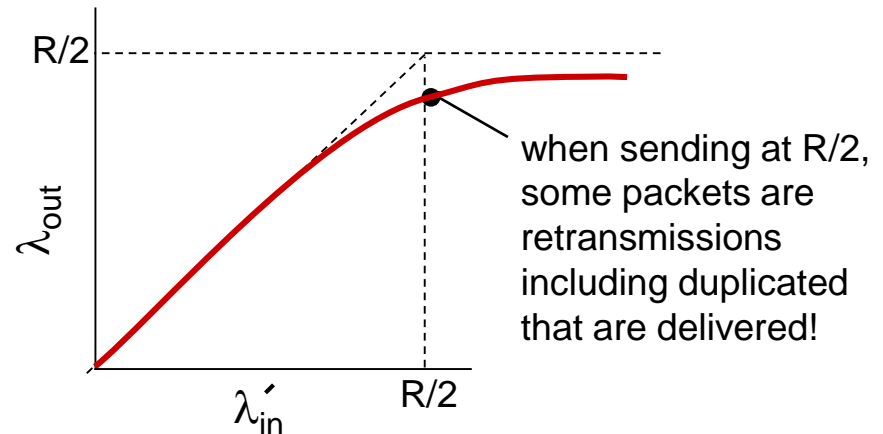

## “costs” of congestion:

- ❖ more work (retrans) for given “goodput”
- ❖ unneeded retransmissions: link carries multiple copies of pkt
  - decreasing goodput

# Causes/costs of congestion: scenario 3

- ❖ four senders
- ❖ multihop paths
- ❖ timeout/retransmit

Q: what happens as  $\lambda_{in}$  and  $\lambda'_{in}$  increase ?

A: as red  $\lambda'_{in}$  increases, all arriving blue pkts at upper queue are dropped, blue throughput  $\rightarrow 0$

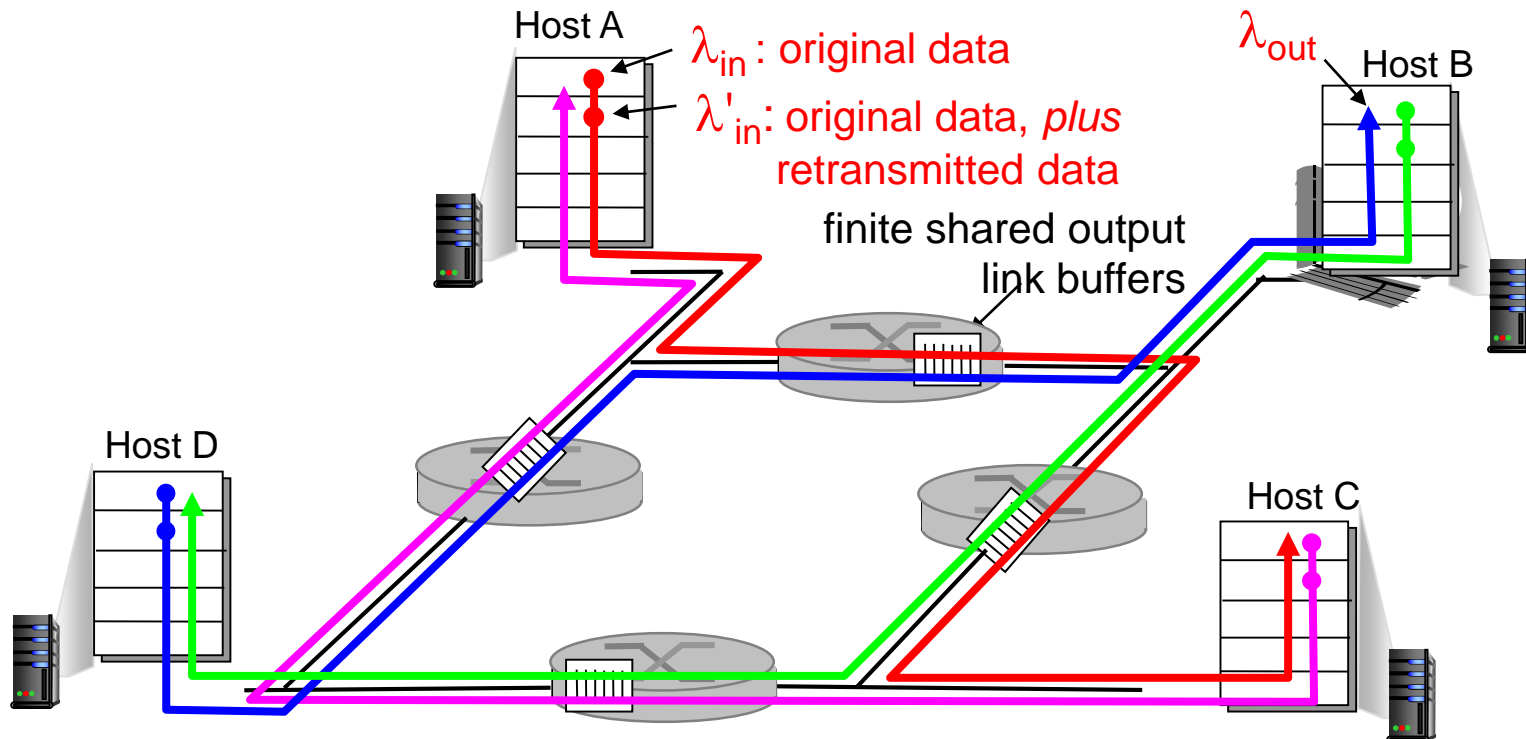

# Causes/costs of congestion: scenario 3

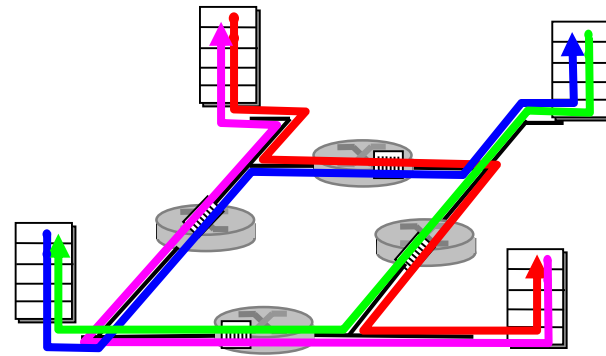
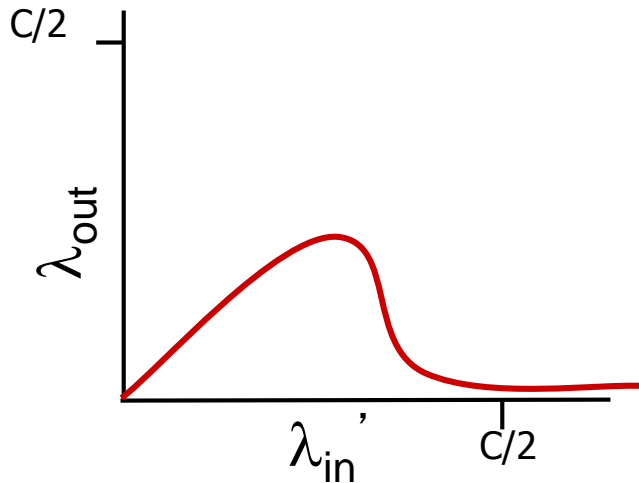

another “cost” of congestion:

- ❖ when packet dropped, any “upstream transmission capacity used for that packet was wasted!

# Approaches towards congestion control

two broad approaches towards congestion control:

## end-end congestion control:

- ❖ no explicit feedback from network
- ❖ congestion inferred from end-system observed loss, delay
- ❖ approach taken by TCP

## network-assisted congestion control:

- ❖ routers provide feedback to end systems
  - single bit indicating congestion (SNA, DECbit, TCP/IP ECN, ATM)
  - explicit rate for sender to send at

# Case study: ATM ABR congestion control

## ABR: available bit rate:

- ❖ “elastic service”:  
*meaning rate can be changed reacting to traffic*
- ❖ if sender's path “underloaded”:
  - sender should use available bandwidth
- ❖ if sender's path congested:
  - sender throttled to minimum guaranteed rate

## RM (resource management) cells:

- ❖ sent by sender, interspersed with data cells
- ❖ bits in RM cell set by switches (“*network-assisted*”)
  - *NI bit*: no increase in rate (mild congestion)
  - *CI bit*: congestion indication
- ❖ RM cells returned to sender by receiver, with bits intact

# Case study: ATM ABR congestion control

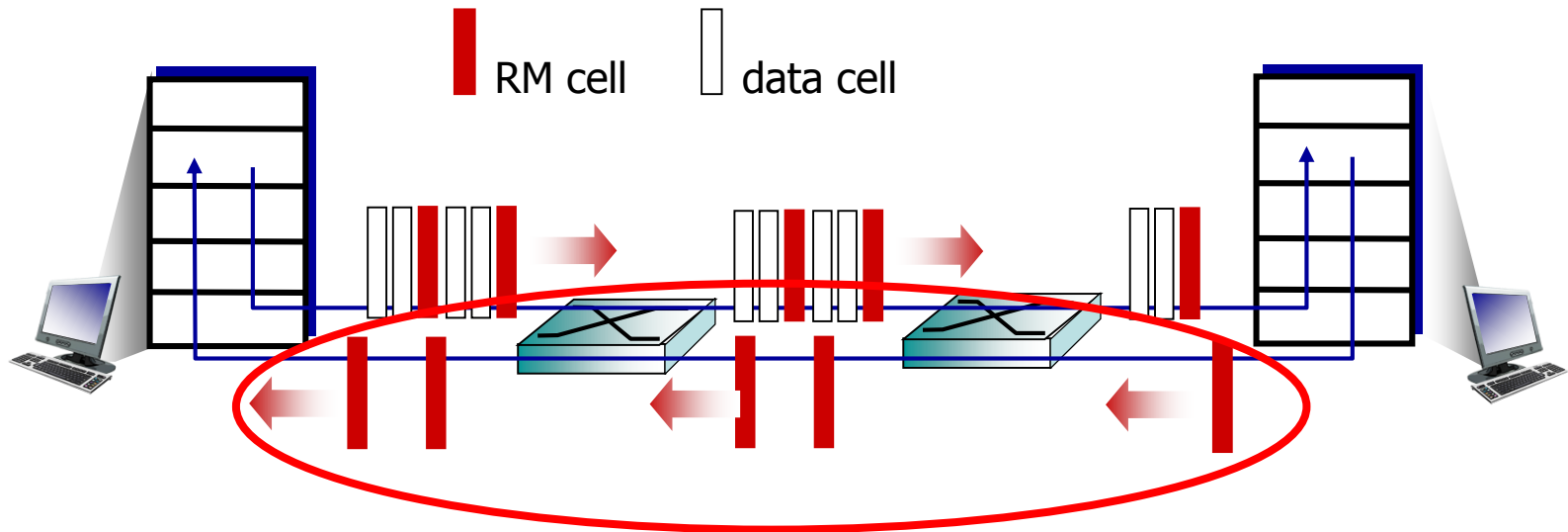

- ❖ two-byte ER (explicit rate) field in RM cell
  - congested switch may lower ER value in cell – *because we added RM cells*
  - senders' send rate thus max supportable rate on path
- ❖ EFCI bit in data cells: set to 1 in congested switch
  - if data cell preceding RM cell has EFCI set, receiver sets CI bit in returned RM cell

# TCP congestion control: additive increase multiplicative decrease

- ❖ *approach*: sender increases transmission rate (window size), probing for usable bandwidth, until loss occurs
  - *additive increase*: increase **cwnd** by 1 MSS every RTT until loss detected
  - *multiplicative decrease*: cut **cwnd** in half after loss

AIMD saw tooth behavior: probing for bandwidth

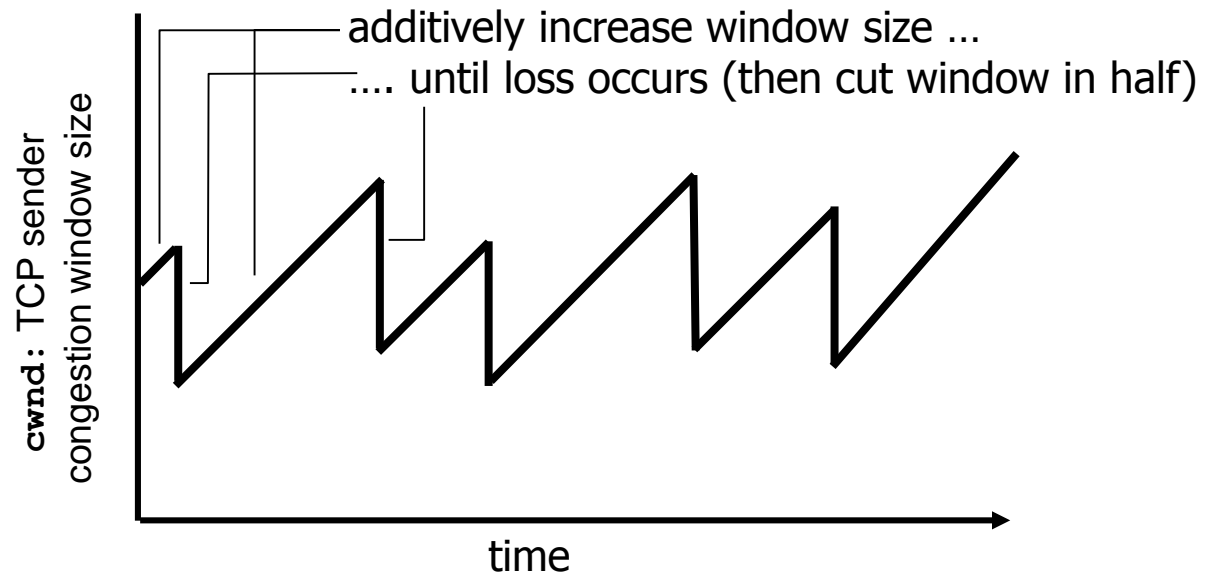

# TCP Congestion Control: details

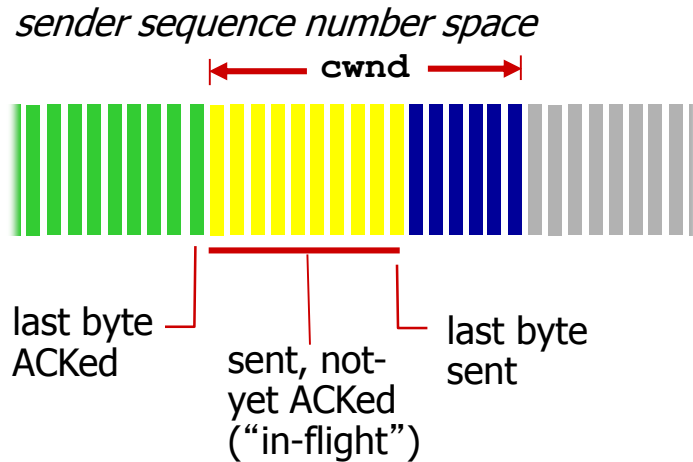

- ❖ sender limits transmission:

$$\text{LastByteSent} - \text{LastByteAked} \leq \text{cwnd}$$

- ❖ **cwnd** is dynamic, function of perceived network congestion

TCP sending rate:

- ❖ roughly: send cwnd bytes, wait RTT for ACKS, then send more bytes

$$\text{rate} \approx \frac{\text{cwnd}}{\text{RTT}} \text{ bytes/sec}$$

# TCP Slow Start

- ❖ when connection begins, increase rate exponentially until first loss event:
  - initially `cwnd` = 1 MSS (**Max Seg Size**)
  - double `cwnd` every RTT
  - done by incrementing `cwnd` for every ACK received
- ❖ summary: initial rate is slow but ramps up exponentially fast: **1,2,4,8,16**

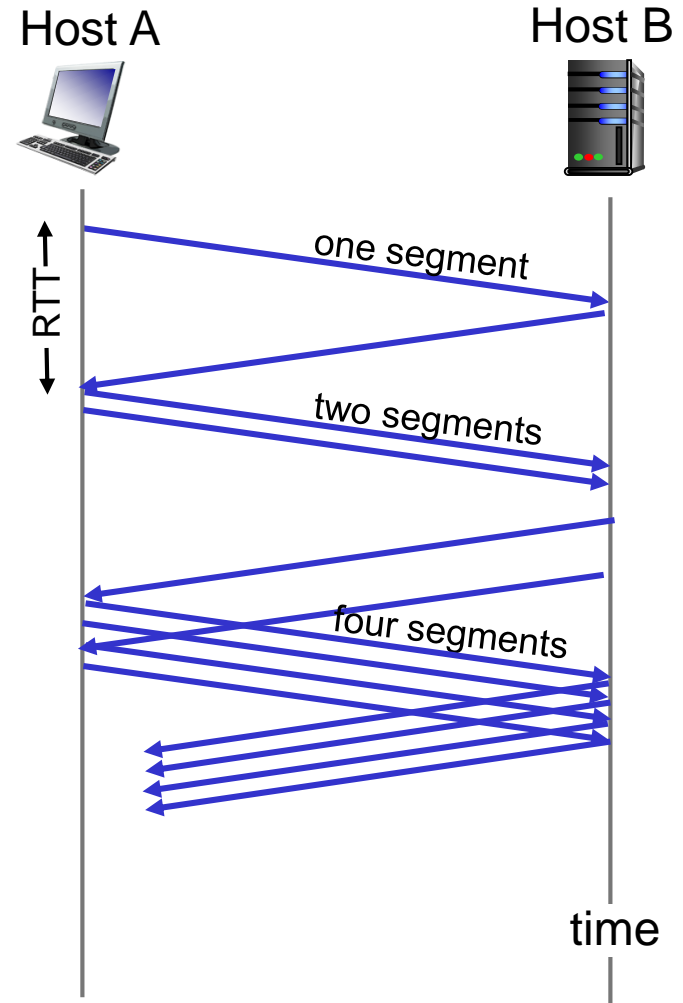

# TCP: detecting, reacting to loss

- ❖ loss indicated by timeout:
  - `cwnd` set to 1 MSS;
  - window then *grows exponentially (as in slow start) to threshold, then grows linearly*
- ❖ **loss indicated by 3 duplicate ACKs: TCP Reno-**  
*incorporated fast recovery*
  - dup ACKs indicate network capable of delivering some segments
  - `cwnd` is cut in half window then grows linearly
- ❖ TCP Tahoe always sets `cwnd` to 1 (timeout or 3 duplicate acks)

# TCP: switching from slow start to CA

**Q:** When should the exponential increase switch to linear?

**A:** When **cwnd** gets to 1/2 of its value before timeout.

## Implementation:

- ❖ variable **ssthresh**
- ❖ on loss event, **ssthresh** is set to 1/2 of **cwnd** just before loss event

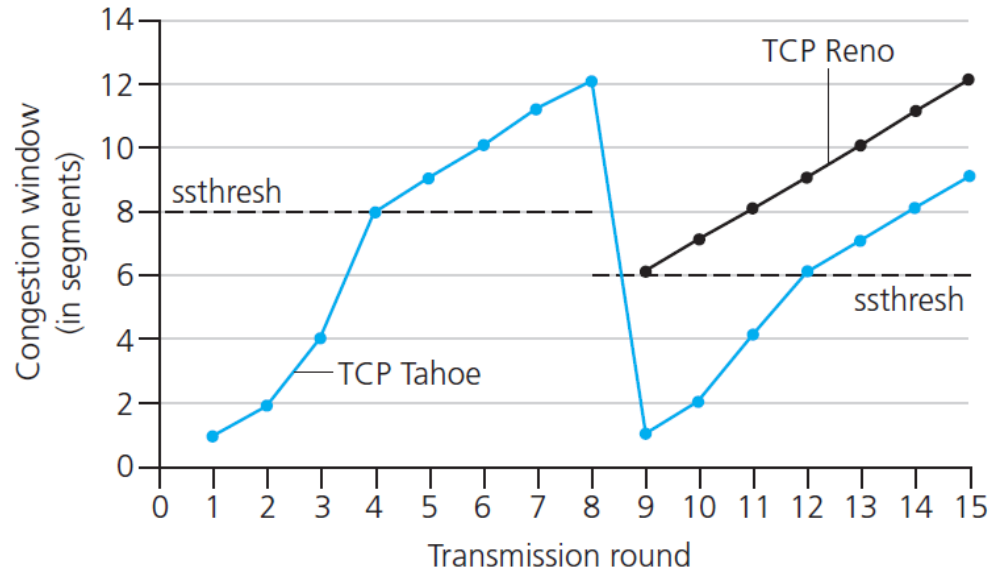

# Summary: TCP Congestion Control

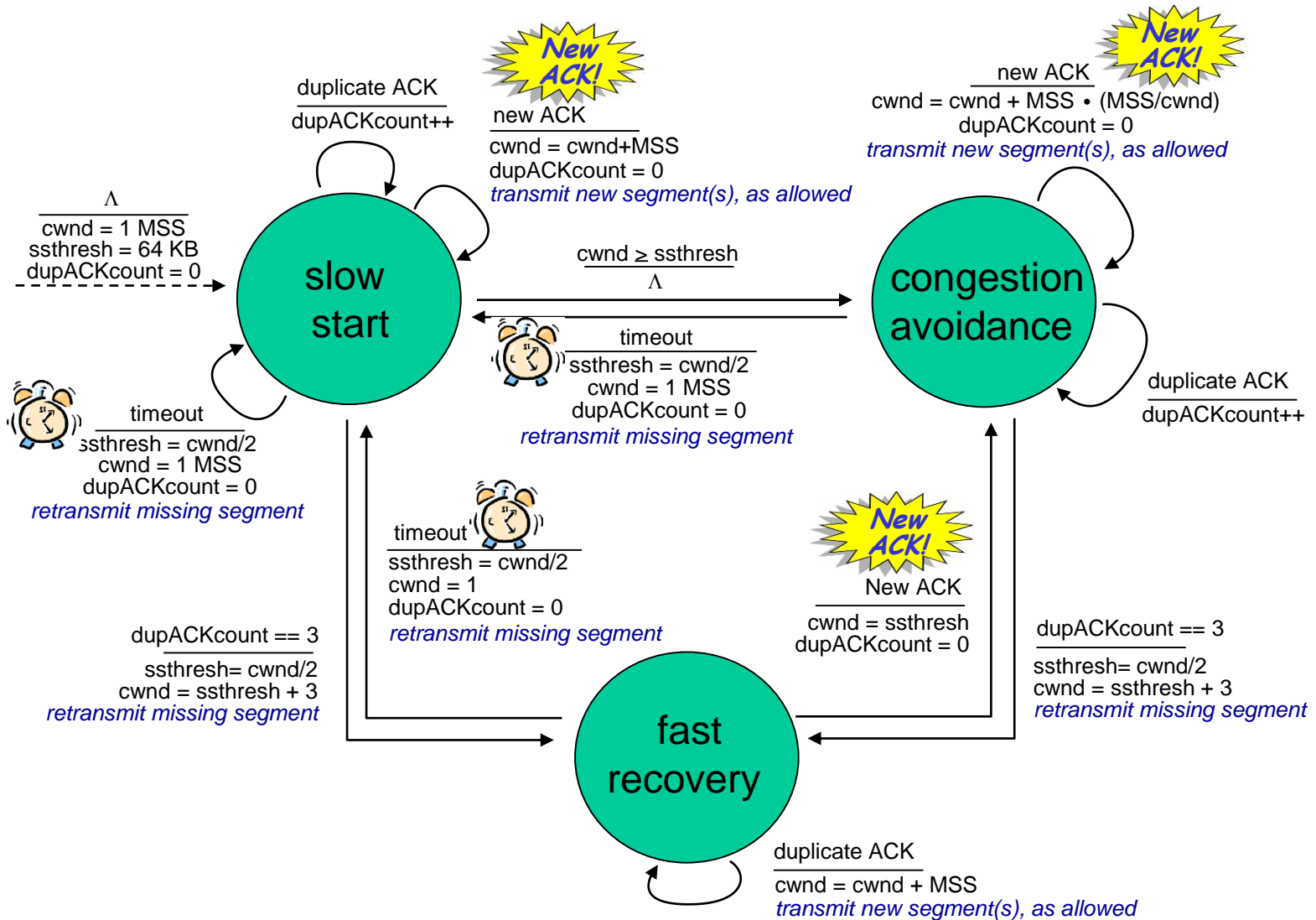

# TCP throughput

- ❖ avg. TCP thruput as function of window size, RTT?
  - ignore slow start, assume always data to send
- ❖ **W: window size** (measured in bytes) **where loss occurs**
  - avg. window size (# in-flight bytes) is  $\frac{3}{4} W$
  - avg. thruput is  $\frac{3}{4}W$  per RTT

$$\text{avg TCP thruput} = \frac{3}{4} \frac{W}{\text{RTT}} \text{ bytes/sec}$$

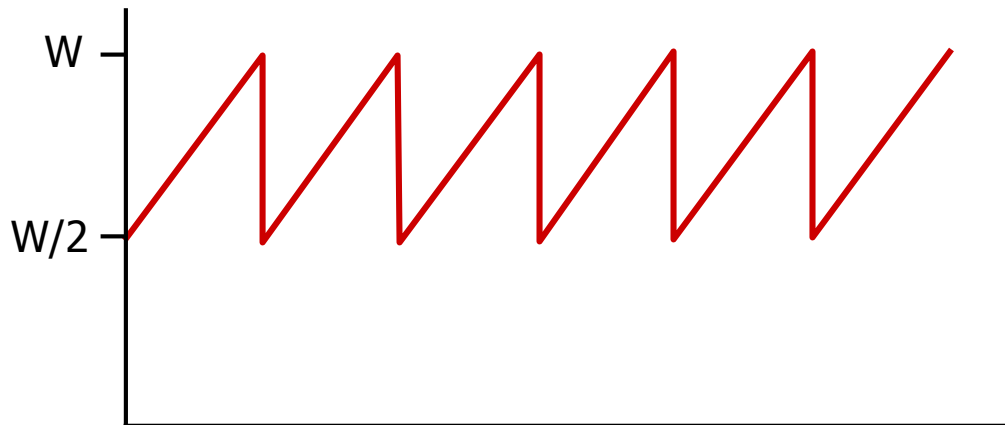

# TCP Futures: TCP over “long, fat pipes”

- ❖ example: 1500 byte segments, 100ms RTT, want 10 Gbps throughput
- ❖ requires  $W = 83,333$  in-flight segments
- ❖ throughput in terms of segment loss probability,  $L$  [Mathis 1997]:

$$\text{TCP throughput} = \frac{1.22 \cdot \text{MSS}}{\text{RTT} \sqrt{L}}$$

→ to achieve 10 Gbps throughput, need a loss rate of  $L = 2 \cdot 10^{-10}$  – *a very small loss rate!*

- ❖ new versions of TCP for high-speed

Throughput =  $\frac{3}{4} (W/\text{RTT})$   
Throughput = 10Gbps  
RTT = 100msec  
1 byte = 8 bits  
RTT = Return Path

$$W = \text{Throughput} * \frac{4}{3} * \text{RTT} \\ = 1333333.333$$

Then divided by 8 for size in bits

$$W = 1333333.333/8 = \\ 1666666.667$$

Then divided by 2 for segments travelling one-way only

$$W = 1666666.667/2 = 83,333.33$$

# TCP Fairness

*fairness goal:* if  $K$  TCP sessions share same bottleneck link of bandwidth  $R$ , each should have average rate of  $R/K$

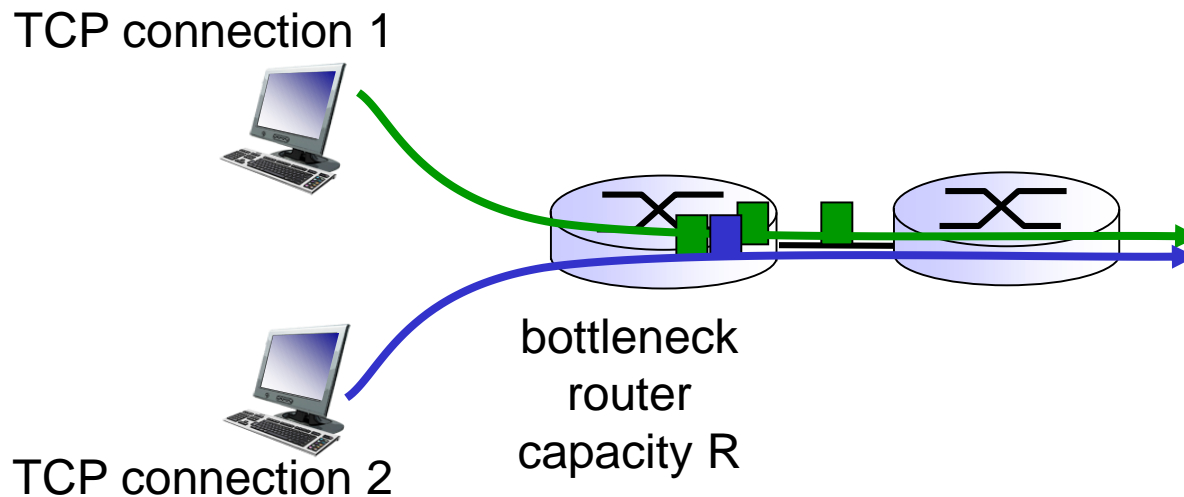

# Why is TCP fair?

two competing sessions:

- ❖ additive increase gives slope of 1, as throughput increases
- ❖ multiplicative decrease decreases throughput proportionally

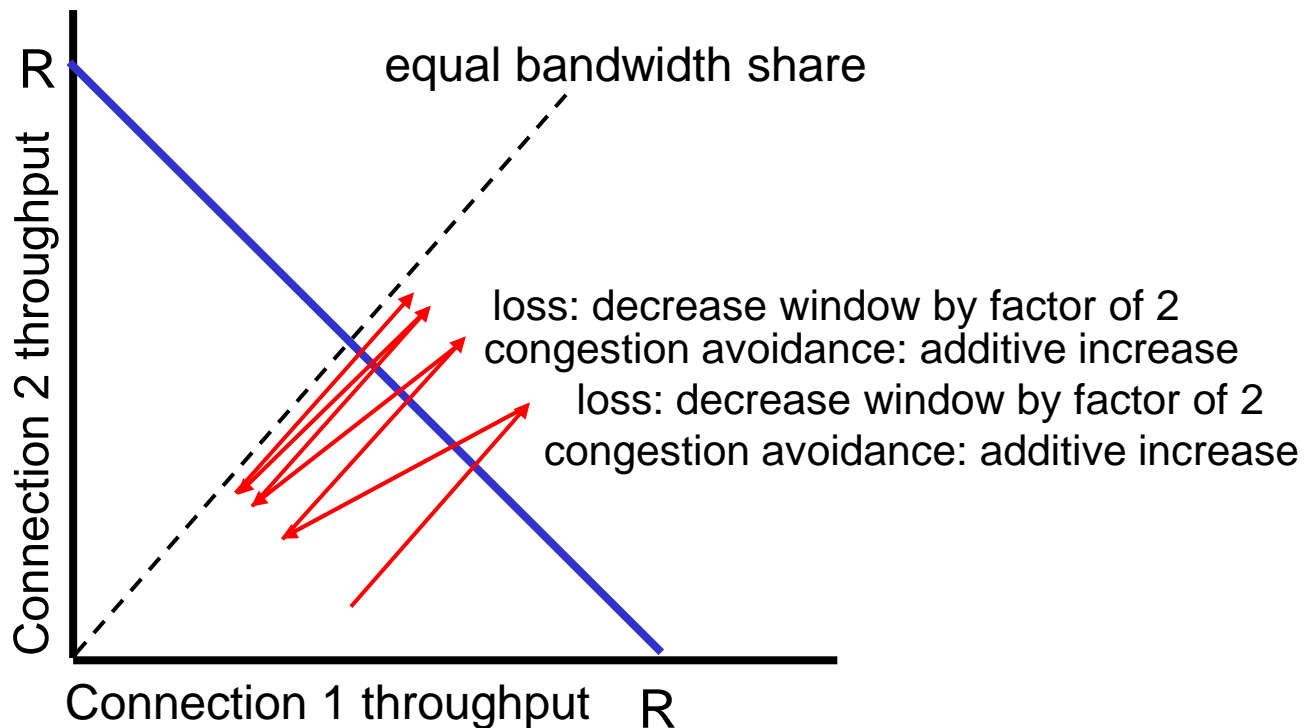

# Fairness (more)

## *Fairness and UDP*

- ❖ multimedia apps often do not use TCP
  - do not want rate throttled by congestion control
- ❖ instead use UDP:
  - send audio/video at constant rate, tolerate packet loss

## *Fairness, parallel TCP connections*

- ❖ application can open multiple parallel connections between two hosts
- ❖ web browsers do this
- ❖ e.g., link of rate  $R$  with 9 existing connections:
  - new app asks for 1 TCP, gets rate  $R/10$
  - new app asks for 11 TCPs, gets  $R/2$

# Chapter 3: summary

- ❖ principles behind transport layer services:
  - multiplexing, demultiplexing
  - reliable data transfer
  - flow control
  - congestion control
- ❖ instantiation, implementation in the Internet
  - UDP
  - TCP

## next:

- ❖ leaving the network “edge” (application, transport layers)
- ❖ into the network “core”